

READ ENTIRE GUIDE BEFORE STARTING INSTALLATION

Important Notice: Verify correct luminaire was received with correct color temperature, voltage, and wattage before cutting or installing. ALUZ will not be responsible if incorrect luminaire is installed.

END VIEWS / DIMENSIONS



Dry or Damp Location
(No Visible Screws)

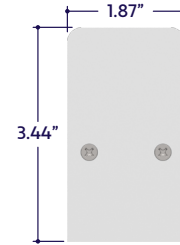

Wet Location
(Visible Screws)

GENERAL FEATURES

Applications	Surface Mount Direct View
Lens	100% Frosted (No Pixelation: Line of Light)
Length	Built to Order: Custom lengths up to 8' (No Seams) Specify Overall Length (Minimum: 2', Maximum: 8') Example: 7'8" = One 7'8" luminaire (Custom Length) Example: 3'2" = One 3'2" luminaire (Custom Length) Example: 13'6" = 8' + 5'6" Example: 23'8" = 8' + 8' + 7'8"
Construction	Aluminum Extrusion
Weight	1.09 lbs per Foot
Mounting	Mounting Plates (Sold Separately)
Listing	Dry, Damp, or Wet Location UL1598, CSA C22.2#250.0 UL8750, CSA250 UL2108, 67.1.9, 60.4, CSA C22.2 #9
Driver	Integral (Driver on Board)
Closest Rating	Up to 4 Watts per Foot Maximum
Temperature Ratings	Operating / Startup: -20° to 48°C (-4° to 120°F) Storage: -40° to 76°C (-40° to 170°F)

Installation Link

ELECTRICAL

Dimming	0-10V, DMX, DALI
Maximum Run (Line Voltage Integral Driver)	80' (4W), 64' (5W), 53' (6W), 40' (8W), 26' (12W)
Luminaire Voltage	120V - 277V (UNV)

PRODUCT INFORMATION

- Lighting for direct view and accent lighting.
- Line Voltage 120-277VAC (**UNV**) integral drivers .
- Long life, energy efficient LEDs.
- Choose from a variety of LED colors and whites.
- Can be ordered to specific lengths for when exact dimensions are known.

ELECTRICAL REQUIREMENTS

- Line voltage luminaires do not require a remote driver
- Maximum load per line voltage luminaire is 320 watts per circuit

INSTALLATION TOOLS REQUIRED

- Electric Hammer Drill
- 14.4 to 28 Volt Cordless Drill
- Phillips Bits
- Utility Knife
- Electrical Cord
- Marker
- Wire Stripper
- Long Nose Pliers
- Drill Bits - Concrete or Wood
- Electrical Three Ways
- Safety Glasses
- Measuring Tape
- Laser Line or Chalk Line

WARNING

When using luminaires for any application, basic safety precautions should always be followed to reduce the risk of fire, electric shock, and personal injury. Luminaires must be installed in accordance with the NEC or CEC as applicable. ALUZ will not be responsible for damage or malfunction caused by the following:

- Ensure power is off before installation begins, during replacements, additions, or repairs.
- Do not use luminaires if damaged, such as broken boards, loose connections, or frayed wire insulation. Inspect before installing.
- Do not install luminaires in hazardous locations.
- Do not cover luminaires with any material. Covering may cause LEDs to overheat, melt, or ignite.
- Do not paint on or over fixture lens or LEDs. Paint or any other substance on lens or LEDs will cause a shift in color temperature.
- Soffit must be evenly painted with a neutral white to avoid color shift.
- Do not modify luminaires in the field.
- Do not overlap luminaires in any way. (Fig. 1)
- Luminaires have line voltage risk of shock. Consult factory for any malfunctions. Do not attempt to repair.
- Only use luminaire with specified rated voltages. Do not exceed the specified voltage for any luminaire.
- Do not use extrusion as a raceway for additional wire. Non-factory feed through wires inside luminaire will void warranty.
- Ground Fault Circuit Interrupter (GFCI) protections should be provided on circuits or outlets when luminaire is used for outdoor applications.
- Surge protector must be set up for electrical power system to avoid damaging lighting system.
- Do not make wiring connections without referring to wiring diagrams.
- Do not cut wire while energized. (Fig. 2)
- Do not exceed maximum run lengths.
- Always follow sequence labeling for continuous runs. Continuous run segments are labeled in alphabetical order.
- Polarity of continuous run segments must be aligned.
- Do not assemble continuous runs prior to installing into mounting clips. Each segment must be installed one by one into mounting clips. The weight of the assembled segments will put strain on junctions, causing the board, pin, or terminals to break.
- Do not install continuous runs without a mounting clip at each junction between two segments.
- Do not secure luminaire with nails or like means that might damage the wiring inside. Only secure by using mounting clips.
- Do not mount luminaire inside tanks or enclosures of any kind.
- Do not install downward facing luminaires without set screws.
- Do not use improper screw head type on mounting clips. It will cause the mounting clip to open up and become dysfunctional.
- Do not modify mounting clips.
- Do not weld mounting clips to surface. Mounting clips must be mechanically attached with screws appropriate for mounting surface and weight of luminaire.
- Do not mount fixture with less than the minimum number of mounting clips required. See mounting clips section for details.
- Do not install mounting clips on uneven surfaces. Use shims to level out height of mounting clips if necessary.
- Do not install mounting clips after luminaires have been assembled. Install mounting clips first, then install luminaire into mounting clips.
- Do not force luminaire into a space that is too small.
- Do not force luminaire with cord grip into soffit. (Fig. 3)
- Do not install luminaire at an angle within a cove. Only install fixtures straight within a cove. (Fig. 4)
- Do not bend extrusion around radius.
- Do not submerge dry or wet location luminaire in any liquid.
- Do not install wet location in outdoor coves without proper drainage. (Fig. 5)
- Do not install luminaire in any area that is continuously exposed to flowing or pooling water, such as underneath drain pipes, sprinklers, fountains, misters, etc.
- Do not cut, puncture, or penetrate aluminum housing, end caps, or lens covers.
- Do not drop, bang, or rest weight upon luminaire.
- Do not apply excessive pressure to any part of luminaire.
- Do not remove end caps from luminaire.
- Do not bend power cord or continuous connector past permitted bend radius. Bending past permitted bend radius will break the seal of the cordgrip or damage the insulation. (Fig. 6)
- Wet Location: 3.5" minimum bend radius
- Dry Location: 1.5" minimum bend radius
- Do not install in places where the power cord is subject to continuous flexing.
- Do not twist continuous connector or power cord.
- Do not hold, carry, or suspend luminaire by the power cord.
- Do not install on ceilings without mounting clips and set screws. (Fig. 7)

FIGURES

Figure 1

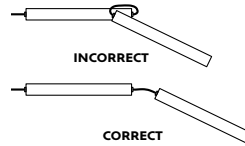

Figure 2

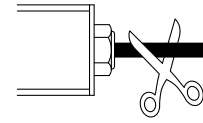

Figure 3

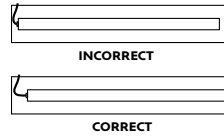

Figure 4

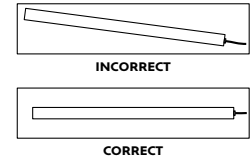

Figure 5

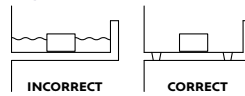

Figure 6

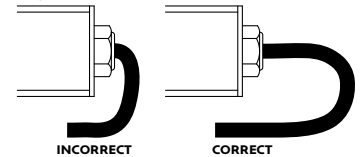
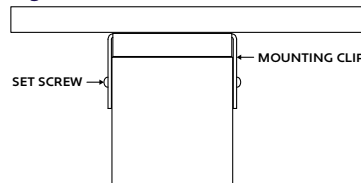

Figure 7



CLEANING MATERIALS

The use of solvents and/or cleaners which are not compatible with polycarbonate will result in the softening, crazing, and/or cracking of the plastic part. This is especially true of polycarbonate lamps and mounting bases which may be under stress in their normal applications.

COMPATIBLE WITH POLYCARBONATE

- Mild soap and water
- Mineral Spirits
- Isobutyl Alcohol
- VM and P Naphtha
- Varsol No.2
- Mexane
- Freone TF and TE-35
- Ethanol
- Dirtex
- 2% Sol. Reg. Joy
- 10% Sol Bon Ami
- White Kerosene
- Methyl Alcohol
- Heptane
- Petroleum Ether / 65°C
- Isopropyl Alcohol
- Lacryl PCL-2035
- Polycarbonate Cleaner

NOT COMPATIBLE WITH POLYCARBONATE

- Trichlor
- Gasoline
- Liquid Detergents
- Acetone
- Carbon Tetrachloride
- Pink Lux (Phosphate free)
- Triclene
- Chlorinated Hydrocarbons
- #1 & #3 Denatured Alcohol
- Methyl Ethyl Keytone (MEK)
- Texize-8006, 8129, 8758
- MIBK
- Liquid Cleaner - 8211
- Toluol
- Agitene
- Benzol
- Ajax
- Kleenol Plastics
- Lysol
- Stanisol Naphtha
- Oils
- Lemon Joy (phosphate free)
- Diversol
- Lestoil

0-10V (Dry or Wet Location)

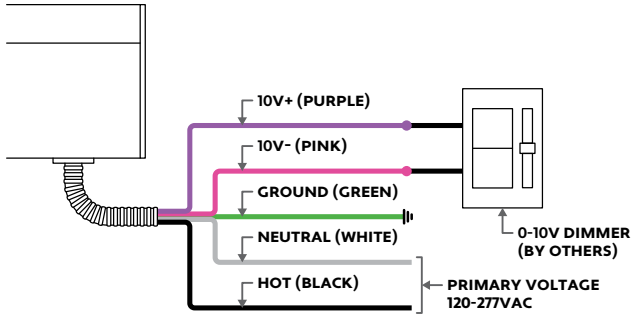

Note: 18/5 Gauge Wire. Outer jacket measures .45". Individual jackets measure .10"

DALI (Dry or Wet Location)

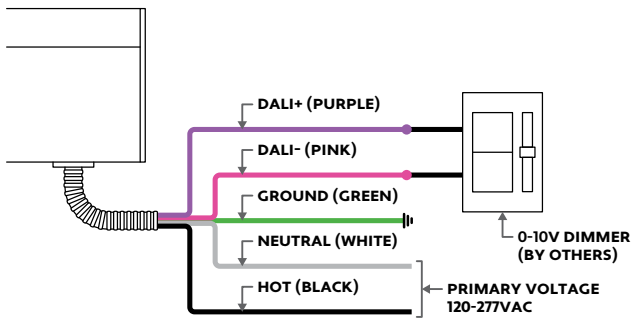

• DALI commissioning to be performed by a third party at time of installation.
ALUZ does not provide DALI commissioning.

Note: 18/5 Gauge Wire. Outer jacket measures .45". Individual jackets measure .10"

DMX (Dry or Wet Location)

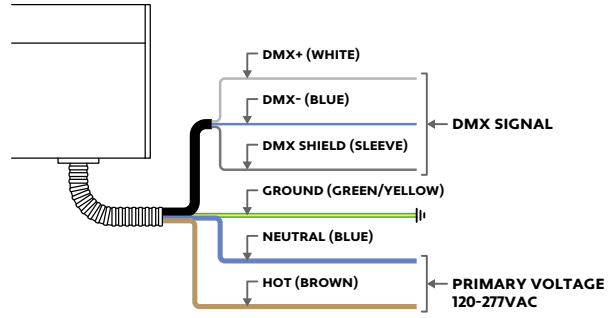

- Consult third party DMX commissioner to modify at time of installation.
- Connection from DMX controller to luminaire must be made using a proper daisy chain connection per DMX-512 / RDM standards.
- Do not make DMX wiring connections in parallel.
- When connecting DMX Shield to a DMX controller terminal, ensure that it is not connected to or touching earth ground, chassis ground, and/or DC power (-) return.

Note: 18/5 Gauge Wire. Outer jacket measures .34". Individual jackets measure .13"

FEED POINT ASSEMBLY (Exploded View)

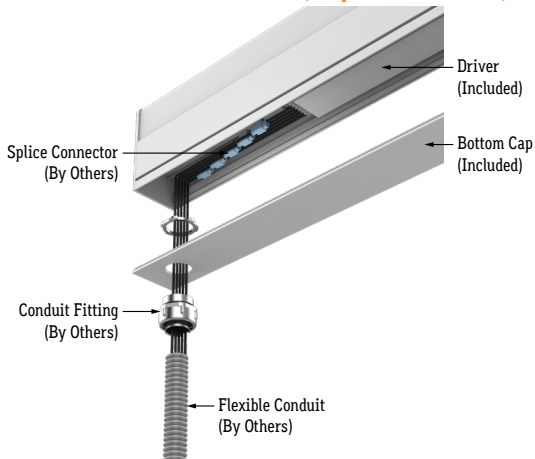

FEED POINT ASSEMBLY (Assembled View)



- Installer must drill a hole in the Bottom Cap to access driver wiring. Make wiring connections through hole to conduit (by others), secured with a conduit fitting rated for the application (by others).
- **Note:** Size, style, and location of conduit and conduit fitting to be determined by installer. Remove bottom cap before drilling. Do not use Mounting Plate holes for conduit. Ensure conduit fitting will not interfere with driver or Mounting Plates. Always use outdoor rated hardware for Wet Located rated luminaires.
- A conduit feed point is required at the beginning of each Dry Location run.
- A conduit feed point is required for each Wet Location luminaire.
- Luminaires may be daisy chained up to max run length.

CONTINUOUS CONNECTIONS (Dry or Damp Location Only)

- 1 Arrange luminaire segments in desired pattern.

Example: 22'4" (8' + 8' + 6'4")

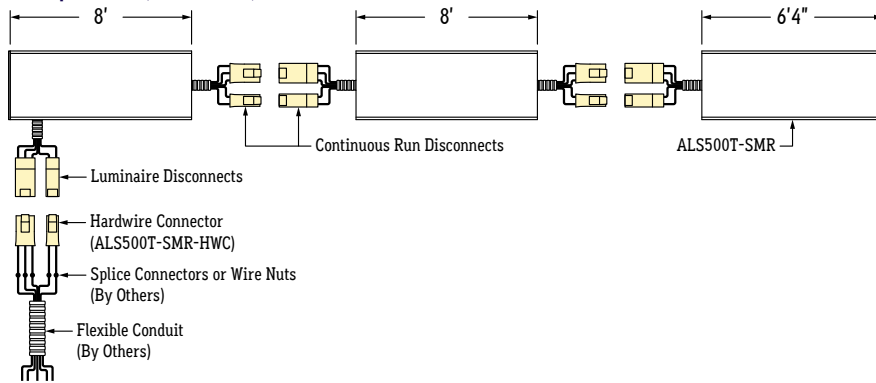

- 2 Connect disconnects between luminaire segments.

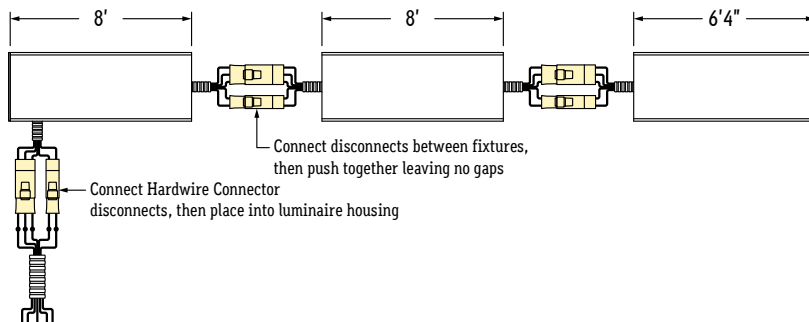

- 3 Push luminaire segments together and snap into mounting plates.

Note: Refer to Mounting Plates page for details on mounting.

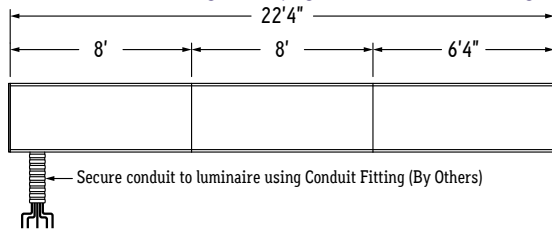

MOUNTING GUIDELINES

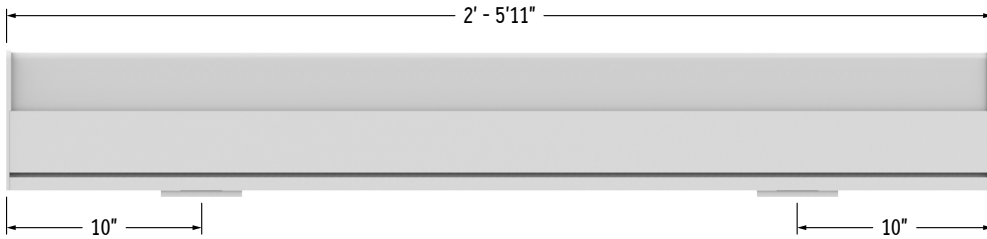

- For luminaires up to 5'11" in length, use 2 mounting plates.
- Each luminaire ships with holes pre-drilled for attaching the mounting plates. Each hole is 10" from the end of luminaire to the center of the hole.

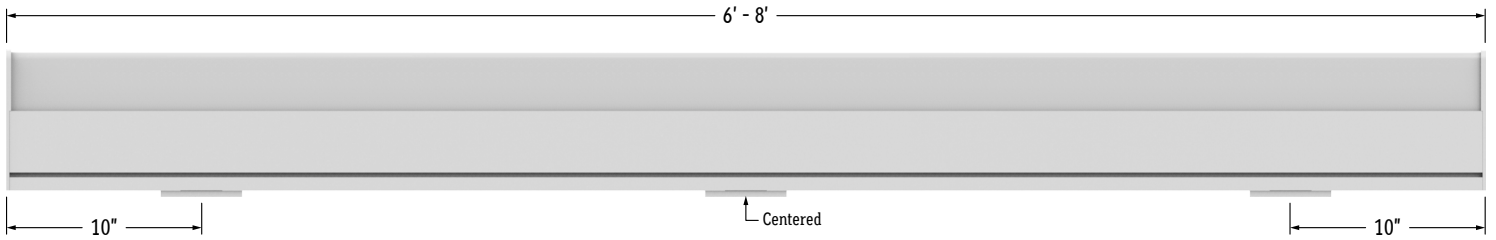

- For luminaires 6' - 8' in length, use 3 mounting plates.
- Each luminaire ships with holes pre-drilled for attaching the mounting plates. Two holes are 10" from the end of fixture to the center of the hole, the third hole is centered on the luminaire.

- 1 Measure area where luminaire will be installed. Use a laser line to create a reference line along installation area, ensuring consistent alignment of mounting plates. Mark location where each mounting plate will be installed along reference line.
- 2 Determine number of mounting plates needed for each run. Refer to next page to ensure correct number of mounting plates are used.
- 3 Mark location where mounting plates will be installed along laser line.

Note: Holes on mounting plates must be aligned with direction of luminaire.

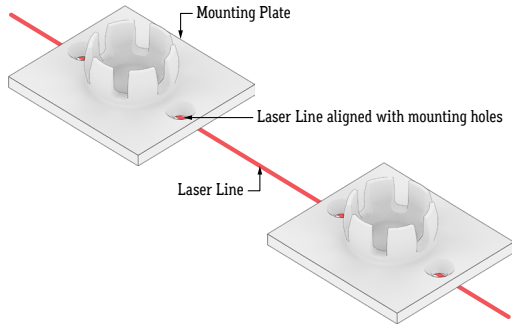

- 4 Lay mounting plates and pre-drill using an appropriate drill bit for surface material and screw size. Each mounting plate must be secured to a solid surface such as a wall stud or secured to drywall using drywall anchors.

Note: Only install Mounting Plates on flat, even surfaces.
- 5 Screw Mounting Plates to surface, then snap luminaire into mounting plates.

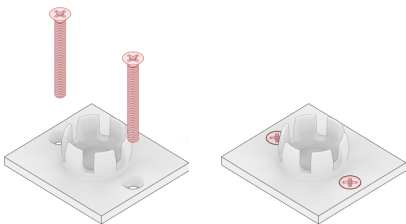

ASSEMBLED DIMENSIONS

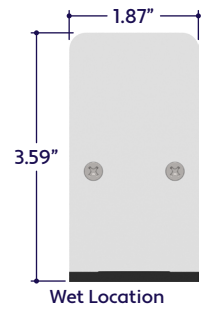
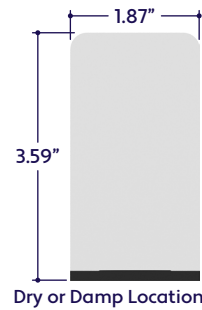

- 1 Measure area where luminaire will be installed. Use a laser line to ensure a straight installation.
Example: 22'4" Run (8' + 8' + 6'4").
- 2 Determine number of Mounting Plates needed for each run. Refer to Mounting Guidelines to ensure correct number of Mounting Plates.
- 3 Mark location where Mounting Plates will be installed along laser line.
Note: Mounting holes on Mounting Plates must be aligned with direction of luminaire.

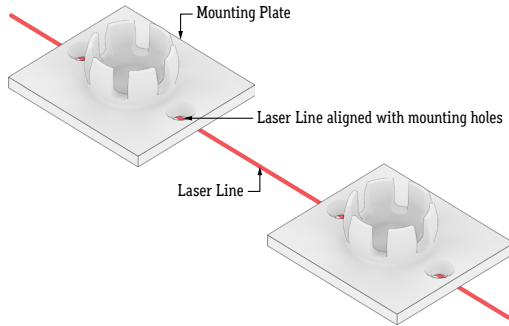

- 4 Lay Mounting Plates and pre-drill using proper drill bit for surface and screw size. Each mounting plate must be secured to a solid surface such as a wall stud or secured to drywall using drywall anchors. Only install Mounting Plates on flat, even surfaces.
Note: Use #8 flat head countersink screw.

- 5 Screw Mounting Plates to surface.

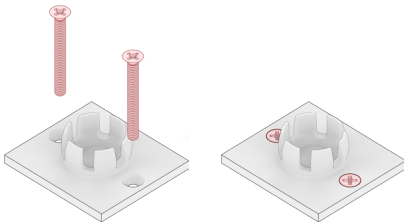

- 6 Determine location where conduit power feed will be fed through the mounting surface. Drill a hole in mounting surface in line with the Mounting Plates, then pull conduit through.
Note: Size of hole to be determined by installer.

- 7 Remove Bottom Cap from luminaire and drill a hole where power will be fed to luminaire.
Note: Refer to Feed Point Assembly for details.

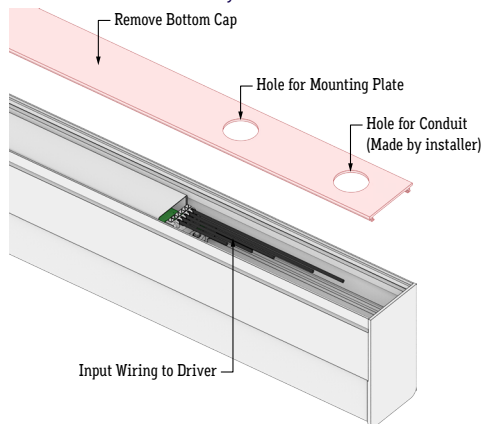

- 8 Making wiring connections from conduit to driver using splice connectors. Use Hardwire Connector or cut off yellow disconnects if applicable. Stagger the splice connectors to save space inside the extrusion. Use a weatherproof Conduit Fitting (by others) to secure conduit to Bottom Cap.
Note: Refer to Wiring Diagrams before connecting wires.

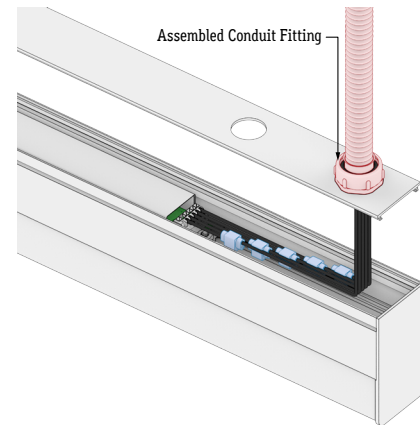
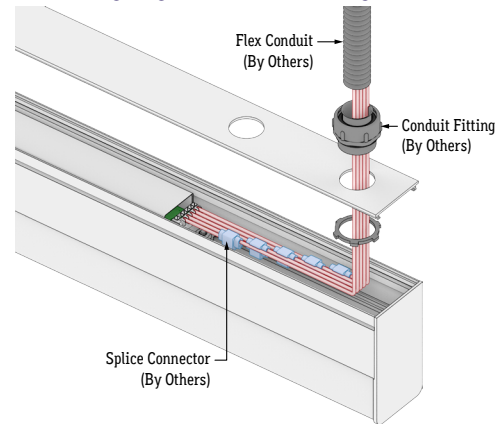

- 9 Replace Bottom Cap onto luminaire.

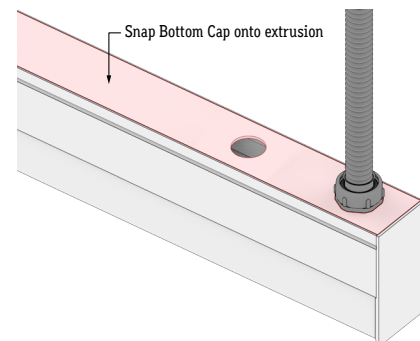

10 If applicable, connect disconnects between luminaires and push together, leaving no gap.

12 Perform a continuity test before connecting luminaire to power source.

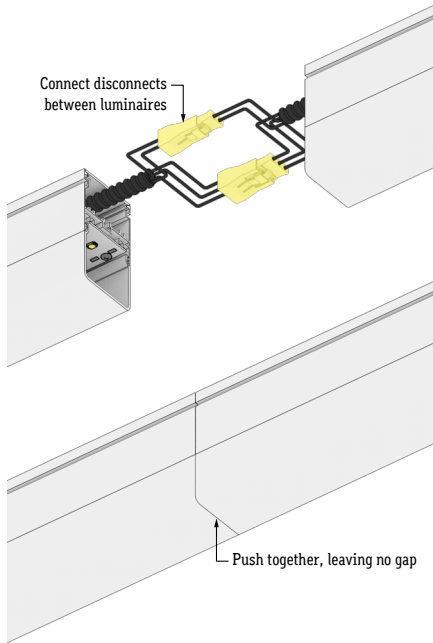

11 Snap luminaires into Mounting Plates after connecting disconnects.

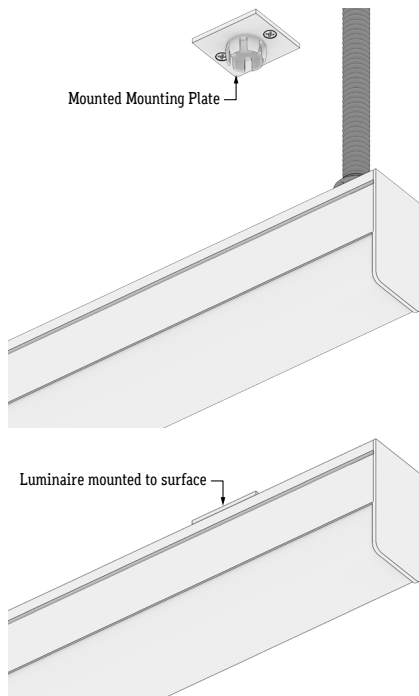

- 1 Measure area where luminaire will be installed. Use a laser line to ensure a straight installation.
Example: 22'4" Run (8' + 8' + 6'4").
Note: To retain Wet Location, luminaire may not be mounted with the lens facing upwards.

- 2 Determine number of Mounting Plates needed for each run.
Refer to Mounting Guidelines to ensure correct number of Mounting Plates.

- 3 Mark location where Mounting Plates will be installed along laser line.
Note: Mounting holes on Mounting Plates must be aligned with direction of luminaire.

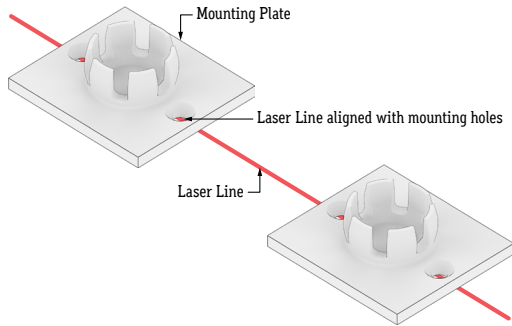

- 4 Lay Mounting Plates and pre-drill using proper drill bit for surface and screw size. Each mounting plate must be secured to a solid surface such as a wall stud or secured to drywall using drywall anchors. Only install Mounting Plates on flat, even surfaces.
Note: Use #8 flat head countersink screw.

- 5 Screw Mounting Plates to surface.

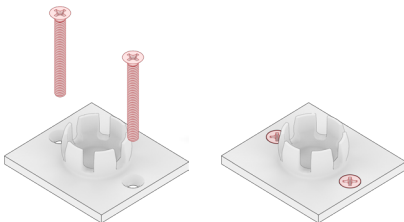

- 6 Determine location where conduit power feed will be fed through the mounting surface. Drill a hole in mounting surface in line with the Mounting Plates, then pull conduit through.
Note: Size of hole to be determined by installer.

- 7 Remove Bottom Cap from luminaire and drill a hole where power will be fed to luminaire.
Note: Refer to Feed Point Assembly for details.

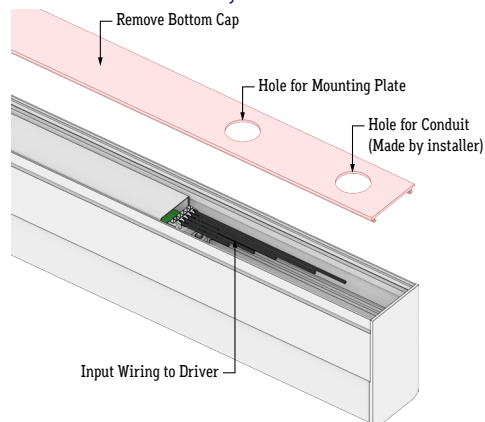

- 8 Making wiring connections from conduit to driver using splice connectors. Use Hardwire Connector or cut off yellow disconnects if applicable. Stagger the splice connectors to save space inside the extrusion. Use a weatherproof Conduit Fitting (by others) to secure conduit to Bottom Cap.
Note: Refer to Wiring Diagrams before connecting wires.

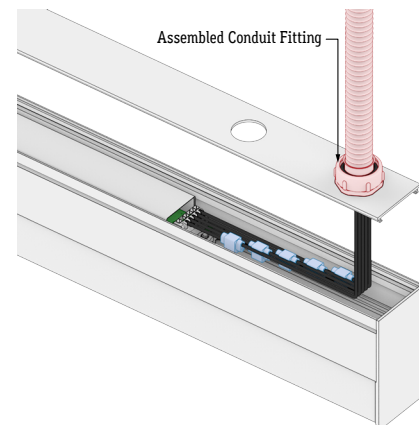
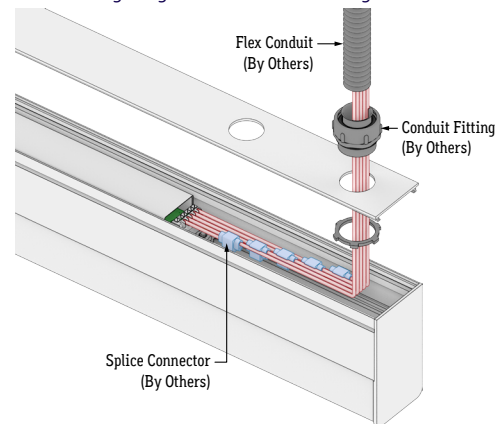

- 9 Replace Bottom Cap onto luminaire.

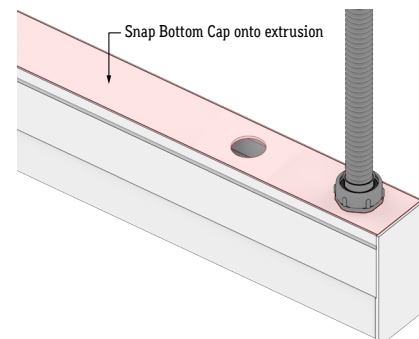

- 10** If applicable, connect disconnects between luminaires and push together, leaving no gap. For Wet Location applications, use the concepts from step 7 - 9 to create a conduit jumper between luminaire segments.

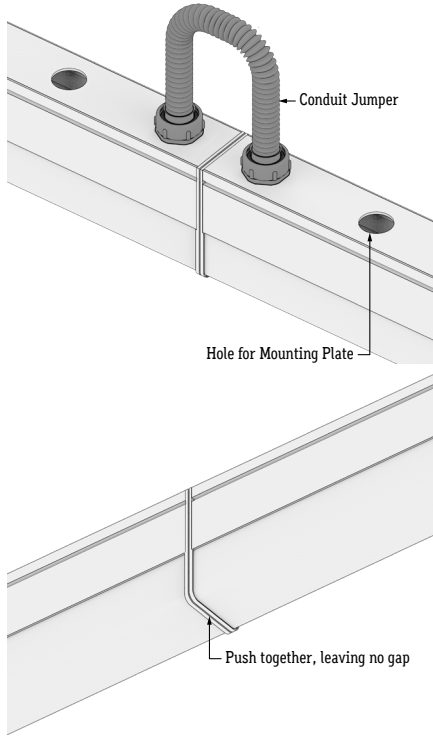

- 11** Snap luminaires into Mounting Plates after connecting luminaire segments.

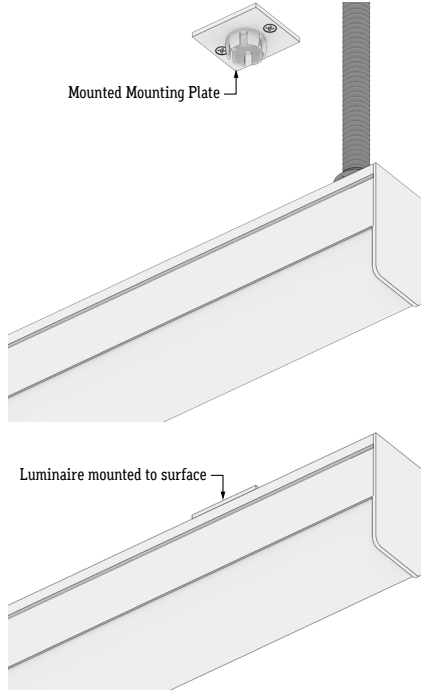

- 1 In the event of a driver failure, the luminaire is easily opened to replace the defective driver.
- 2 Turn off power before beginning. Remove set screws if applicable, then remove luminaire from mounting clips. Turn the segment over and remove bottom cap by using a flathead screwdriver to gently pry the cap away from the housing.

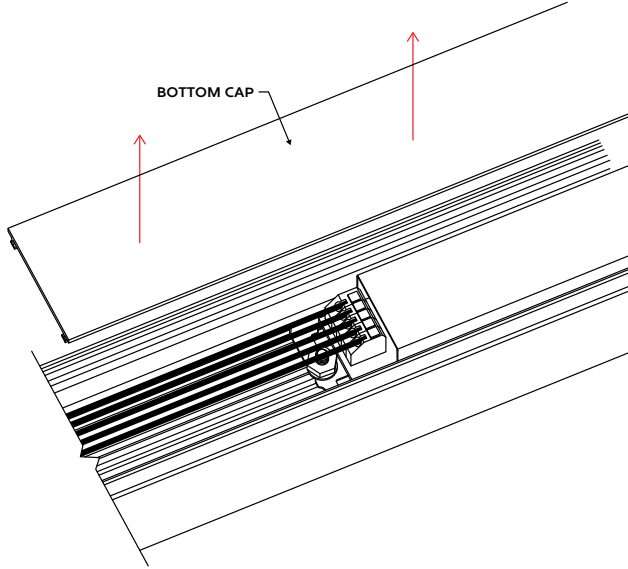

- 3 Push release buttons on terminal block to release wires, then remove wires. Repeat the process on the other end of the driver.

Note: Do not bend, deform, pull, or force wires.

Tip: Take a photo as a reference for the wiring configuration.

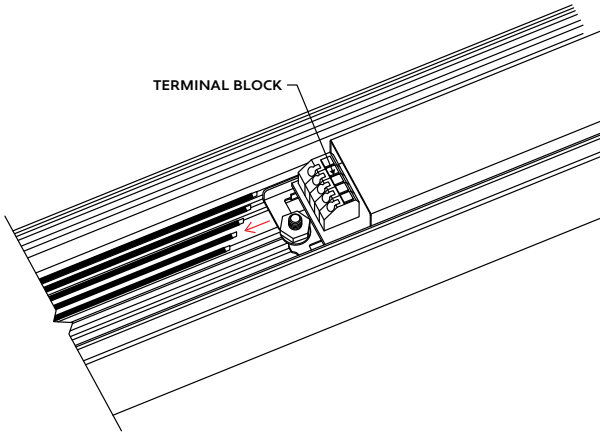

- 4 Loosen hex nut assembly using an 11/32 socket, then slide assembly away from driver to release driver. Do not disassemble the hex nut assembly. Repeat the process on the other end of the driver.

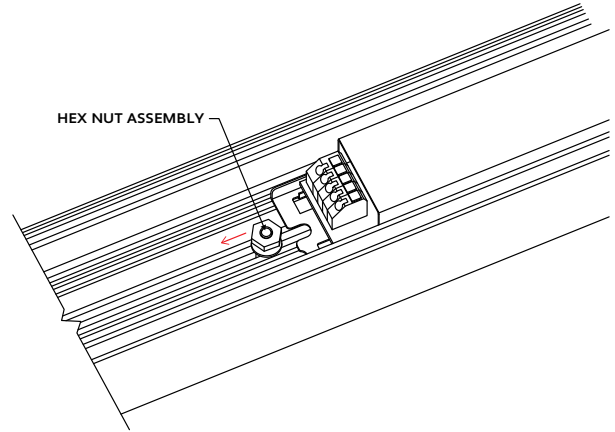

- 5 Remove defective driver from luminaire and replace with a new, identical or similar compatible driver. Mount driver to housing using the hex nut assemblies, then reconnect wires.

Note: Consult factory if uncertain about driver compatibility.

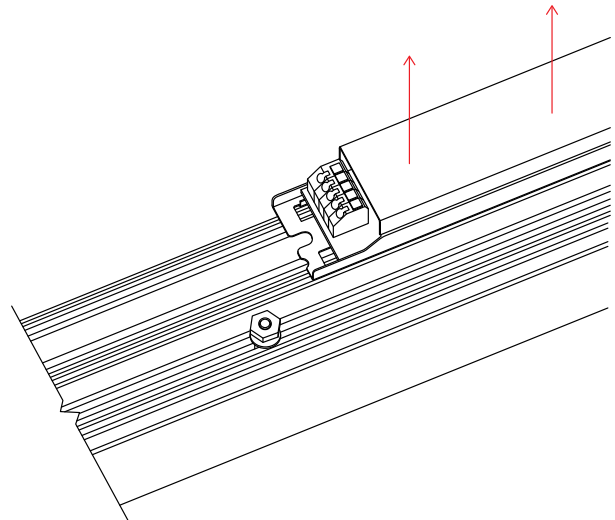

TROUBLESHOOTING TIPS

- Do not reset the breaker multiple times.
- If the unit is overloaded, the breaker will trip, shutting off the driver and lights.
- If the breaker reset button has been held down by hand or any type of pressure, such as duct tape, or if the breaker has been reset multiple times without troubleshooting, the unit will:
 - Burn the driver bobbin.
 - Burn the thermal or magnetic breaker.
 - Burn the driver lead wires due to high amperage caused by overload.
 - Short circuit in line which will not allow the breaker to reset.
 - Damage the lighting.

- 1 Turn off power before beginning. Check for any twisting or damage to the circuit in the LED lightstrip. If there is excessive damage and the circuit is broken, the lightstrip must be replaced.

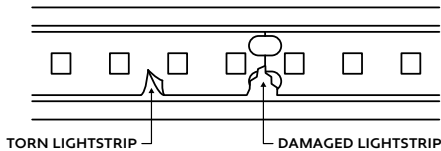

- 2 Check for metal particles or other foreign objects causing the short.

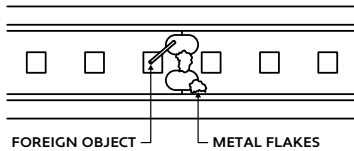

- 3 Check to make sure cuts in the lightstrip are clean and not frayed, causing positive and negative copper pads to touch.

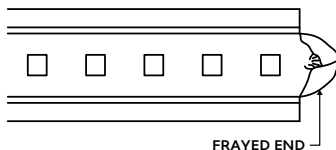

CONTINUITY TEST

A continuity test is performed to determine if electricity can pass through two points on an electrical circuit. This helps identify shorts or malfunctions in the luminaire. Use a multimeter or continuity tester to perform the steps below.

- Always perform a continuity test before connecting to power source.
- Malfunctions are not always as obvious as the lights not turning on.
- A short or malfunction in the line or luminaire will cause damage over time, irreparably damaging the lighting and voiding warranty.

- 1 Turn off power before beginning. Verify power is off by using a non-contact circuit tester (by others). Touch the probe of the tester to the positive wire of the power source. The tester will light up if an electrical current is detected.

- 2 Setup your multimeter tester (by others). First, insert the black probe lead into the COM jack, then insert the red probe lead into the VΩ jack.

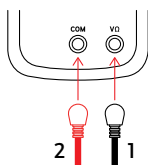

- 3 Measure area where luminaire will be installed. Use a laser line to create a reference line along installation area, ensuring consistent alignment of mounting channels. Mark location where mounting channels will be installed along reference line.

- 4 Touch the red probe to the luminaire extrusion and the black probe to the ground wire (green). If the luminaire is properly grounded, the multimeter will beep, flash, or read 0Ω (ohms). If there is no conductive path, the multimeter will not show any feedback. Troubleshoot to identify the malfunction in the ground wire.

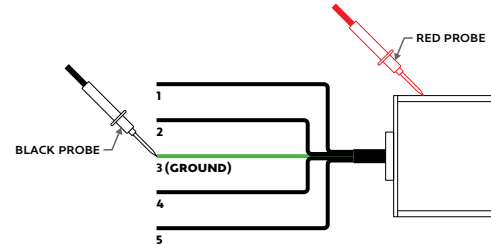

- 5 Touch the red probe to any wire and the black probe to each other wire. Repeat process for each wire. If a conductive path is formed between any of the wires, the multimeter will beep, flash, or read 0Ω (ohms). Troubleshoot to identify the malfunction in the line. If there is no conductive path, the multimeter will not show any feedback.

Example: Check for continuity between Wire 2 and Wire 4

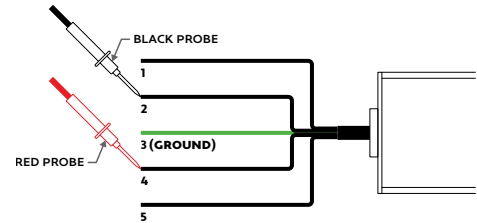

- 6 Touch the red probe to the luminaire housing and the black probe to each wire except ground. If a conductive path is formed between the housing and any of the wires, the multimeter will beep, flash, or read 0Ω (ohms). Troubleshoot to identify the malfunction in the line. If there is no conductive path, the multimeter will not show any feedback.

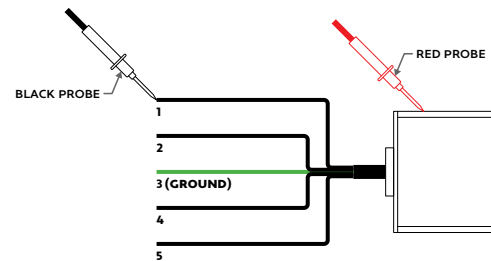

- 7 Set multimeter to AC voltage and test power source. Confirm the correct voltage before connecting luminaire to power source. If the voltage reading is more than 1 volt greater than the marked output voltage, there is a problem with the power source or driver.

- 8 Connect luminaire to power source. If LEDs do not turn on, troubleshoot to find the problem in the line.