

### READ ENTIRE GUIDE BEFORE STARTING INSTALLATION

**Important Notice:** Verify correct luminaire was received with correct color temperature, voltage, and wattage before cutting or installing. ALUZ will not be responsible if incorrect luminaire is installed.

### END VIEWS / DIMENSIONS

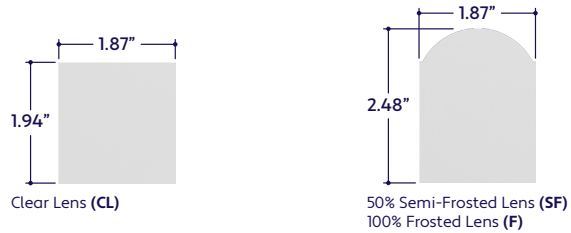

### GENERAL FEATURES

<b>Applications</b>	Indirect and Direct Lighting
<b>Lens</b>	Clear, Frosted, or Semi-Frosted
<b>Length</b>	Built to Order: Standard 4' Lengths and Custom Lengths Specify Overall Length (Minimum: 1'4", Maximum: 8') Example: 7'8" = One 7'8" luminaire (Custom Length) Example: 3'2" = One 3'2" luminaire (Custom Length) Example: 13'6" = 4' + 4' + 4' + 1'6" Example: 23'8" = 4' + 4' + 4' + 4' + 3'8"
<b>Construction</b>	Aluminum Extrusion
<b>Weight</b>	1.18 lbs per foot
<b>Mounting</b>	Mounting Clips (Sold Separately)
<b>Listing</b>	Dry or Damp Location UL1598, CSA C22.2#250.0 UL8750, CSA250 UL2108, 67.1.9, 60.4, CSA C22.2 #9
<b>Driver</b>	Integral (Driver on Board)
<b>Temperature Ratings</b>	Operating / Startup: -20° to 48°C (-4° to 120°F) Storage: -40° to 76°C (-40° to 170°F)
<b>Installation Link</b>	

### ELECTRICAL

<b>Dimming</b>	0-10V, DMX, DALI (Type 6)
<b>Maximum Run (Line Voltage Integral Driver)</b>	100' (1.5W, 2W, 3W) 80' (4W), 64' (5W), 53' (6W), 45' (7W), 26' (12W)
<b>Luminaire Voltage</b>	120V - 277V (UNV)

### PRODUCT INFORMATION

- Lighting for cove, accent, display, and under cabinet
- Line Voltage (Integral Driver)
- Available in 3 Watts up to 7 Watts Per Foot
- Can be ordered to specific lengths when exact dimensions are known

### ELECTRICAL REQUIREMENTS

- Line voltage luminaires do not require a remote driver
- Maximum load per line voltage luminaire is 320 watts per circuit

### INSTALLATION TOOLS REQUIRED

- Electric Hammer Drill
- 14.4 to 28 Volt Cordless Drill
- Phillips Bits
- Utility Knife
- Electrical Cord
- Marker
- Wire Stripper
- Long Nose Pliers
- Drill Bits - Concrete or Wood
- Electrical Three Ways
- Safety Glasses
- Measuring Tape
- Laser Line or Chalk Line

### COMPATIBLE CONTROL INTERFACES

- 0-10V
- DALI2
- DMX
- Acuity Controls / nLight
- eldoLED
- Distech Controls
- Legrand
- Wattstopper
- Pass & Seymour
- Leviton
- Crestron / Cresnet / SolarSync
- Eaton
- Tridonic / Bluetooth

### WARNING

When using luminaires for any application, basic safety precautions should always be followed to reduce the risk of fire, electric shock, and personal injury. Luminaires must be installed in accordance with the NEC or CEC as applicable. ALUZ will not be responsible for damage or malfunction caused by the following:

- Ensure power is off before installation begins, during replacements, additions, or repairs.
- Do not use luminaires if damaged, such as broken boards, loose connections, or frayed wire insulation. Inspect before installing.
- Do not install luminaires in hazardous locations.
- Do not operate outdoor luminaires during daytime hours.
- Do not cover luminaires with any material. Covering may cause LEDs to overheat, melt, or ignite.
- Do not paint on or over fixture lens or LEDs.
- Paint or any other substance on lens or LEDs will cause a shift in color temperature.
- Soffit must be evenly painted with a neutral white to avoid color shift.
- Do not modify luminaires in the field.
- Do not overlap luminaires in any way. (Fig. 1)
- Luminaires have line voltage risk of shock. Consult factory for any malfunctions. Do not attempt to repair.
- Only use luminaire with specified rated voltages. Do not exceed the specified voltage for any luminaire.
- Do not use extrusion as a raceway for additional wire. Non-factory feed through wires inside luminaire will void warranty.
- Ground Fault Circuit Interrupter (GFCI) protections should be provided on circuits or outlets when luminaire is used for outdoor applications.
- Surge protector must be set up for electrical power system to avoid damaging lighting system.
- Do not make wiring connections without referring to wiring diagrams.
- Do not cut wire while energized. (Fig. 2)
- Do not connect DC output from remote drivers in parallel. Parallel connections interfere with dimming capabilities and result in feedback that damages drivers. (Fig. 3)
- Always mount channels and mounting clips on flat, even surfaces.
- Do not exceed maximum run lengths.
- Always follow sequence labeling for continuous runs. Continuous run segments are labeled in alphabetical order.
- Polarity of continuous run segments must be aligned.
- Do not assemble continuous runs prior to installing into mounting clips. Each segment must be installed one by one into mounting clips. The weight of the assembled segments will put strain on junctions, causing the board, pin, or terminals to break.
- Do not install continuous runs without a mounting clip at each junction between two luminaire segments.
- Do not secure luminaire with nails or like means that might damage the wiring inside. Only secure by using mounting clips.
- Do not mount luminaire inside tanks or enclosures of any kind.
- Do not install downward facing luminaires without set screws.
- Do not use improper screw head type on mounting clips. It will cause the mounting clip to open up and become dysfunctional.
- Do not modify mounting clips.
- Do not weld mounting clips to surface. Mounting clips must be mechanically attached with screws appropriate for mounting surface and weight of luminaire.
- Do not mount fixture with less than the minimum number of mounting clips required. See mounting clips section for details.
- Do not install mounting clips on uneven surfaces. Use shims to level out height of mounting clips if necessary.
- Do not install mounting clips after luminaires have been assembled. Install mounting clips first, then install luminaire into mounting clips.
- Do not force luminaire into a space that is too small.
- Do not force luminaire with cord grip into soffit. (Fig. 4)
- Do not install luminaire at an angle within a cove. Only install fixtures straight within a cove. (Fig. 5)
- Do not bend extrusion around radius.
- Do not submerge dry or wet location luminaire in any liquid.
- Do not install wet location in outdoor coves without proper drainage. (Fig. 6)
- Do not install luminaire in any area that is continuously exposed to flowing or pooling water, such as underneath drain pipes, sprinklers, fountains, misters, etc.
- Do not cut, puncture, or penetrate aluminum housing, end caps, or lens covers.
- Do not drop, bang, or rest weight upon luminaire.
- Do not apply excessive pressure to any part of luminaire.
- Do not remove end caps from luminaire.
- Do not bend power cord or continuous connector past permitted bend radius. Bending past permitted bend radius will break the seal of the cordgrip or damage the insulation. 3.5" minimum bend radius for Wet Location. 1.5" minimum bend radius for Dry Location (Fig. 7)
- Do not install in places where the power cord is subject to continuous flexing.
- Do not twist continuous connector or power cord.
- Do not hold, carry, or suspend luminaire by the power cord.
- Do not install on ceilings without mounting clips and set screws. (Fig. 8)

### FIGURES

Figure 1

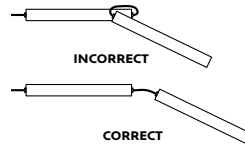

Figure 2

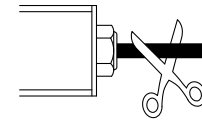

Fig. 3

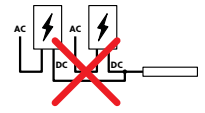

Figure 4

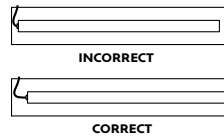

Figure 5

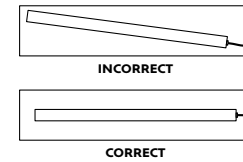

Figure 6

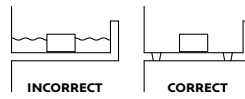

Figure 7

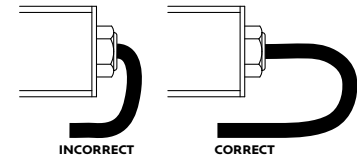
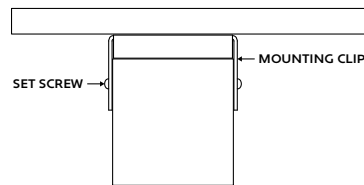

Figure 8



### CLEANING MATERIALS

The use of solvents and/or cleaners which are not compatible with polycarbonate will result in the softening, crazing, and/or cracking of the plastic part. This is especially true of polycarbonate lamps and mounting bases which may be under stress in their normal applications.

### COMPATIBLE WITH POLYCARBONATE

- Mild soap and water
- Mineral Spirits
- Isobutyl Alcohol
- VM and P Naphtha
- Varsol No.2
- Mexane
- Freone TF and TE-35
- Ethanol
- Dirtex
- 2% Sol. Reg. Joy
- 10% Sol Bon Ami
- White Kerosene
- Methyl Alcohol
- Heptane
- Petroleum Ether / 65°C
- Isopropyl Alcohol
- Lacryl PCL-2035
- Polycarbonate Cleaner

### NOT COMPATIBLE WITH POLYCARBONATE

- Trichlor
- Gasoline
- Liquid Detergents
- Acetone
- Carbon Tetrachloride
- Pink Lux (Phosphate free)
- Triclene
- Chlorinated Hydrocarbons
- #1 & #3 Denatured Alcohol
- Methyl Ethyl Keytone (MEK)
- Texize-8006, 8129, 8758
- MIBK
- Liquid Cleaner - 8211
- Toluol
- Agitene
- Benzol
- Ajax
- Kleenol Plastics
- Lysol
- Stanisol Naphtha
- Oils
- Lemon Joy (phosphate free)
- Diversol
- Lestoil

### 0-10V WIRING DIAGRAM (Dry Location Only)

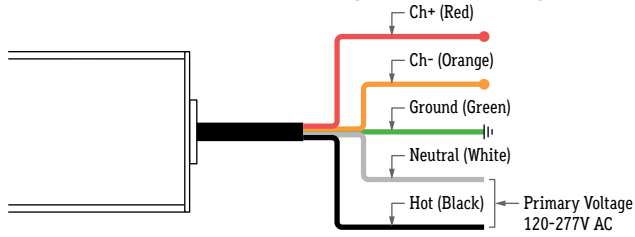

### 0-10V WIRING DIAGRAM (Dry or Damp Location)

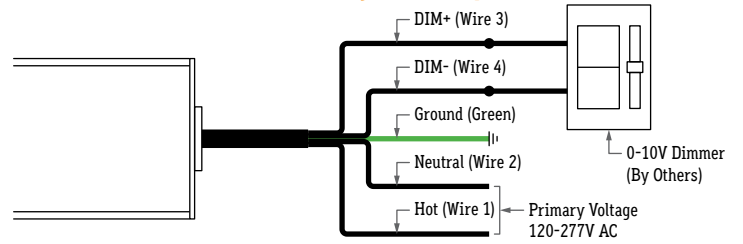

### DMX WIRING DIAGRAM (Dry Location Only)

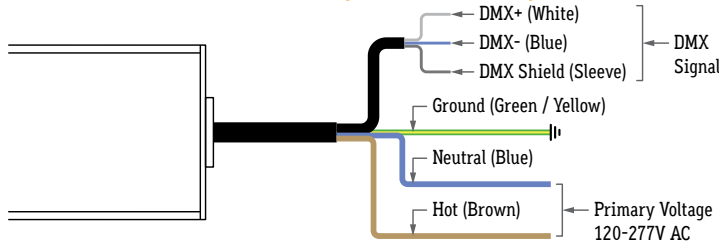

- Consult third party DMX commissioner to modify at time of installation.
- Connection from DMX controller to luminaire must be made using a proper daisy chain connection per DMX-512 / RDM standards.
- Do not make DMX wiring connections in parallel.
- When connecting DMX Shield to a DMX controller terminal, ensure that it is not connected to or touching earth ground, chassis ground, and/or DC power (-) return.

### DALI WIRING DIAGRAM (Dry or Damp Location)

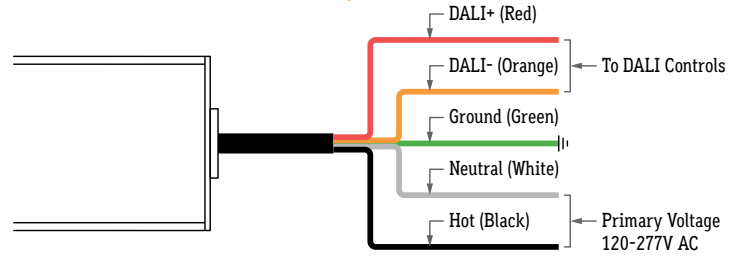

- DALI commissioning to be performed by a third party at time of installation. ALUZ does not provide DALI commissioning.

**MC-1**

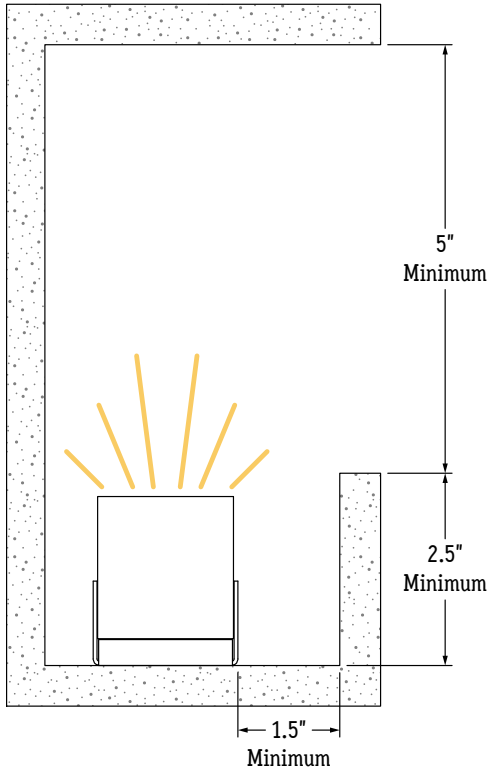

**MC-2**

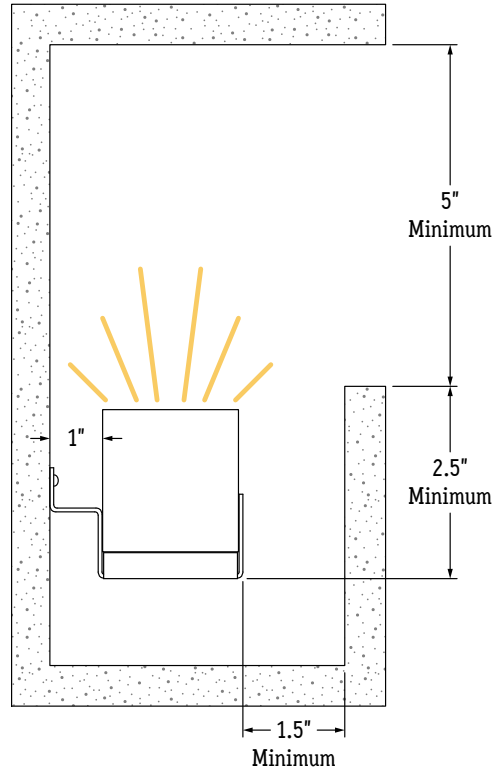

**MC-3**

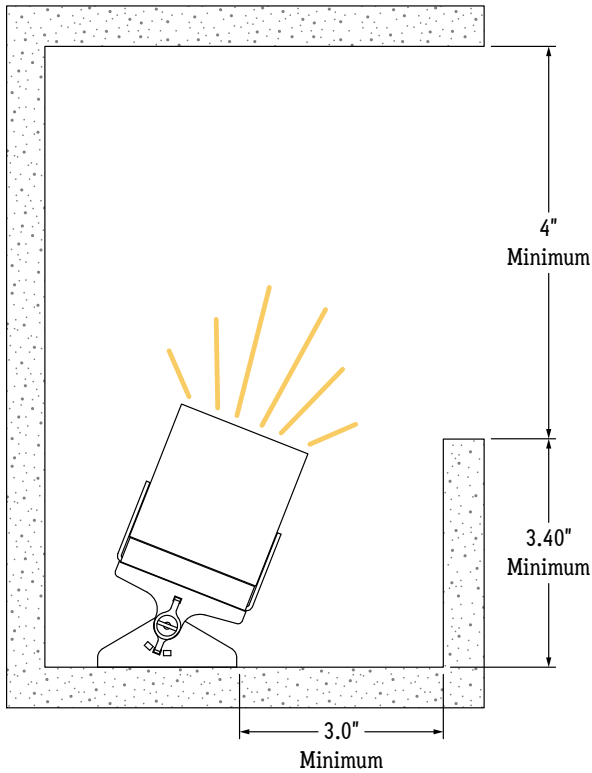

**MC-4-X (X = Specified Length)**

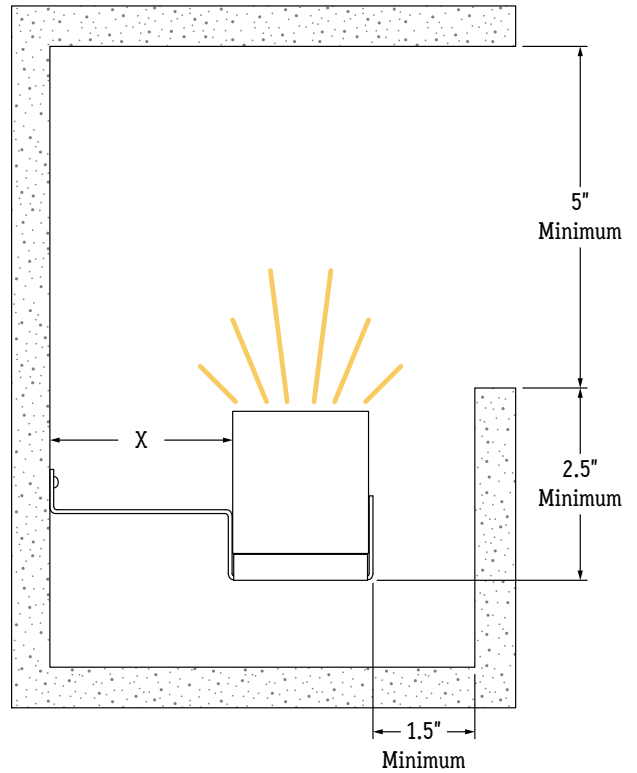

- 1 Measure area where luminaire will be installed. Use a laser line to create a reference line along installation area, ensuring consistent alignment of mounting clips. Mark location where each mounting clip will be installed along reference line.
- 2 Use 1 mounting clip every 2', rounded up. Use a minimum of 2 mounting clips per luminaire segment. For vertical applications, create a stopper at the bottom of the run to prevent sliding.
- 3 Use a mounting clip at the junction between two luminaire segments. **Example:** 20' Run.

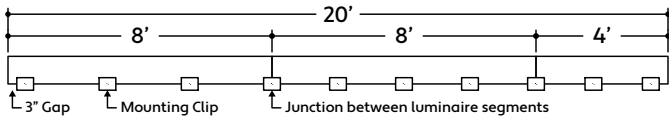

- 4 Lay mounting clips along reference line and pre-drill using an appropriate drill bit for surface material and screw size. Typical screw size is 8/32 x 1".  
**Note:** Allow 1/4" clearance on each side of mounting clip to account for lateral expansion. Only install mounting clips on flat, even surfaces.

- 5a Screw MC-1 to surface, then snap luminaire into mounting clips.

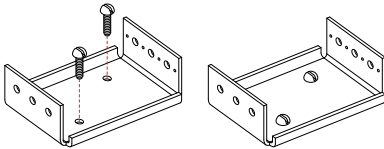

- 5b Screw MC-2 to surface, then snap luminaire into mounting clips.

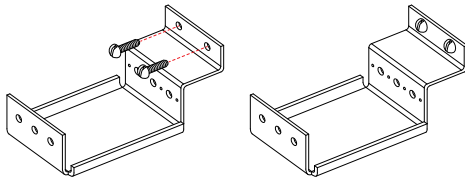

- 5c Screw MC-3 to surface, then snap luminaire into mounting clips.

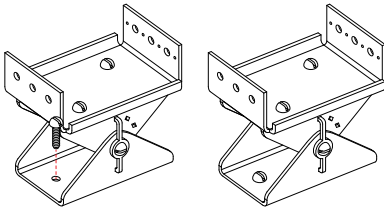

- 5d Screw MC-4 to surface, then snap luminaire into mounting clips.

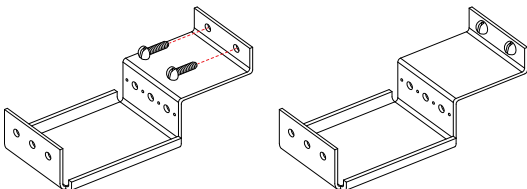

- 6 Install set screws to each mounting clip, if applicable. Set screws are required for downward facing, outward facing, and vertically mounted applications. Install set screws on the outer holes of each mounting clip that connects two luminaire segments.

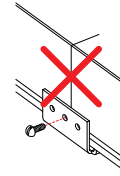
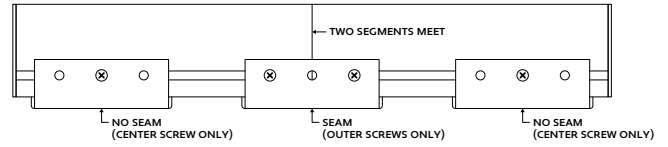

**INCORRECT:**  
Do not install center screw at seam

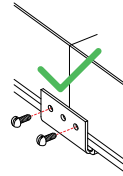

**CORRECT:**  
Install outer screws on each side of mounting clip at the seam

### ASSEMBLED DIMENSIONS

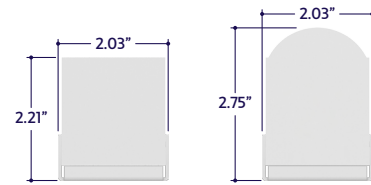

MC-1

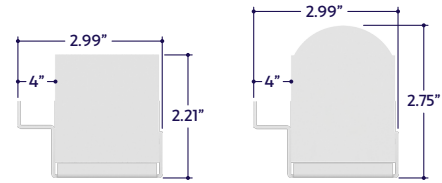

MC-2

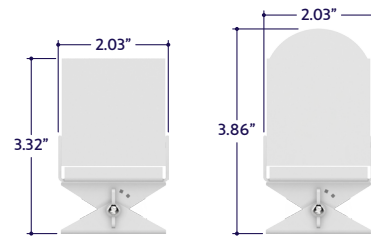

MC-3

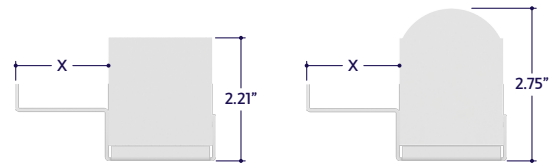

MC-4

- 1 Measure area where fixture will be installed. Use a laser line to create a reference line along installation area, ensuring consistent alignment mounting clips.
- 2 Mark location where mounting clips will be installed.  
**Note:** The number of required mounting clips differs for dry and wet location products. Verify number of mounting clips is appropriate for installation environment before installing. Do not install fixtures with inadequate number of mounting clips
- 3 Lay mounting clips along reference line and pre-drill using an appropriate drill bit for surface and screw size.  
**Recommendation:** 8/32 x 1" countersink screw.  
**Note:** Allow 1/4" clearance for lateral expansion of assembled mounting clips. Only install mounting clips on flat, even surfaces.

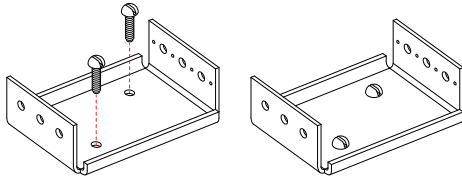

- 4 If applicable, connect disconnects between fixtures and push together, leaving no gaps. Use a mounting clip at the junction between fixture segments.

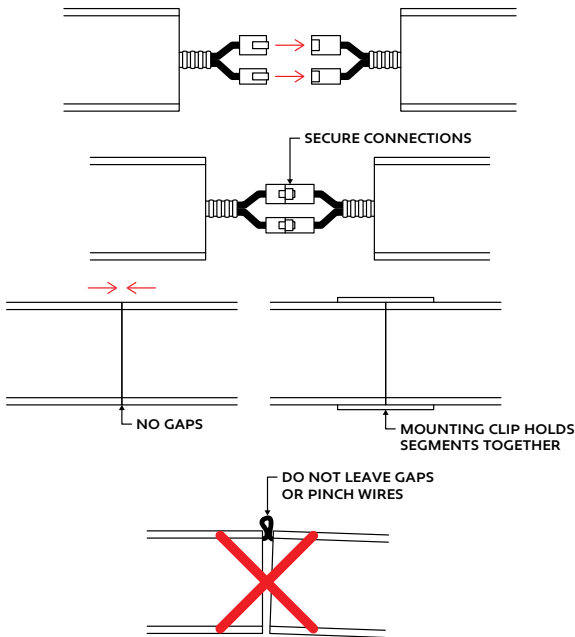

- 5 If applicable, connect jumper cable disconnects between fixtures. Install end cap screws to connect end cap to fixture.

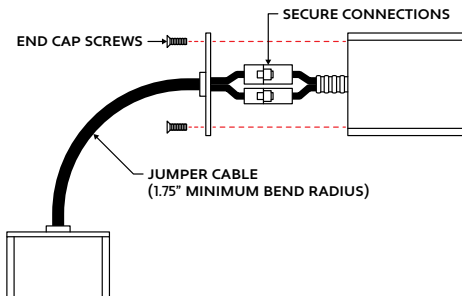

- 6 Screw mounting clips to surface, then snap fixtures into mounting clips.  
**Note:** Set screws are required for downward and outward facing applications.

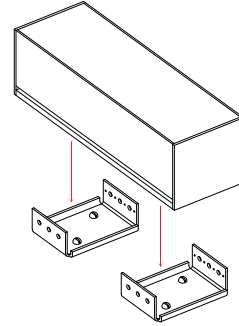

- 7 If applicable, connect power connector disconnects to fixture. Install end cap screws to connect end cap to fixture.  
**Note:** Standard fixture provided with 1 factory installed 6' power connector and 1 end cap at the end of each run. The power connector can be easily relocated by unscrewing end cap and undoing disconnects.

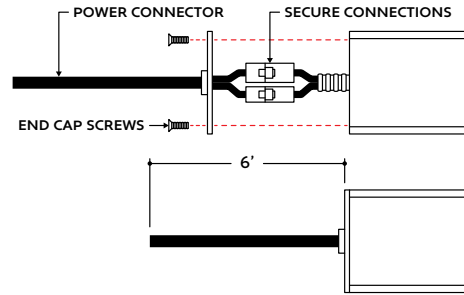

- 8 If applicable, connect power disconnects to j-box. Use power conduit for hardwiring. Connect wires using wire nuts and cap off any unused wires. Ensure connections are secure, then install end cap screws to connect end cap to fixture.  
**Note:** Wires and conduit for hardwiring supplied by others. Wires to be determined by installer in order to identify line voltage and 0-10V signal wires.

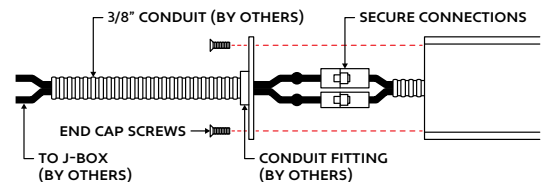

- 9 Perform a continuity test before connecting to power source.  
**Note:** Refer to **Continuity Test** for details.
- 10 Connect fixture to power source and testing lighting and dimming functions. After lighting is confirmed to be working, replace top cover to each fixture segments, ensuring it snaps securely in place.

- 1 In the event of a driver failure, the luminaire is easily opened to replace the defective driver.
- 2 Turn off power before beginning. Remove set screws if applicable, then remove luminaire from mounting clips. Turn the segment over and remove bottom cap by using a flathead screwdriver to gently pry the cap away from the housing.

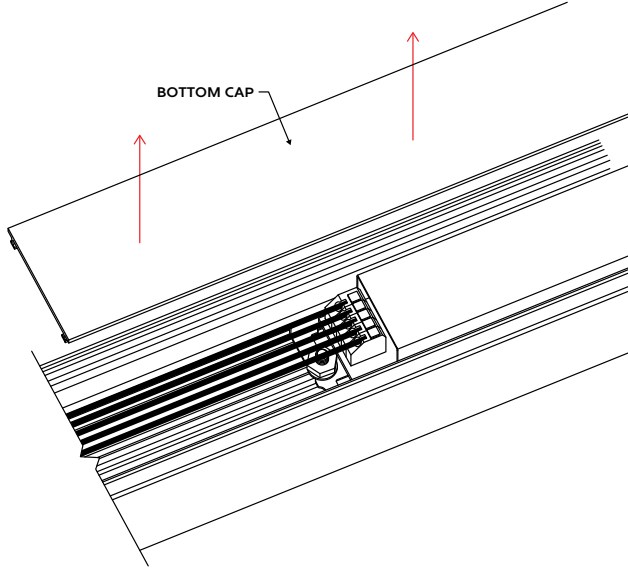

- 4 Loosen hex nut assembly using an 11/32 socket, then slide assembly away from driver to release driver. Do not disassemble the hex nut assembly. Repeat the process on the other end of the driver.

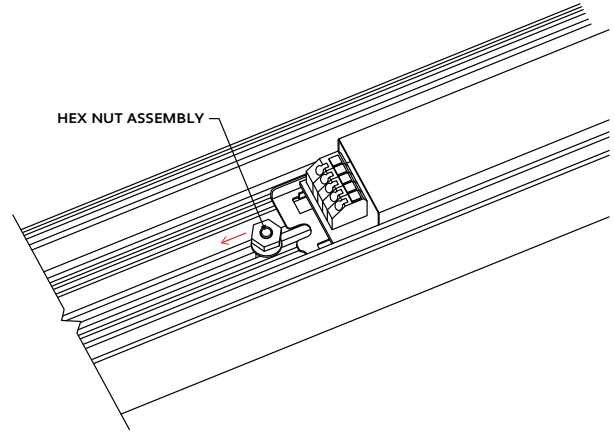

- 3 Push release buttons on terminal block to release wires, then remove wires. Repeat the process on the other end of the driver.  
**Note:** Do not bend, deform, pull, or force wires.  
**Tip:** Take a photo as a reference for the wiring configuration.

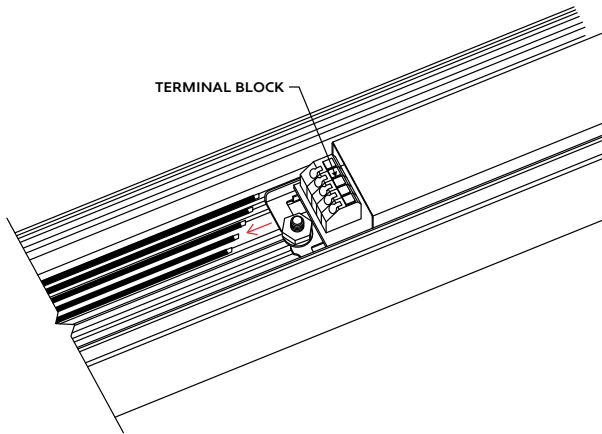

- 5 Remove defective driver from luminaire and replace with a new, identical or similar compatible driver. Mount driver to housing using the hex nut assemblies, then reconnect wires.  
**Note:** Consult factory if uncertain about driver compatibility.

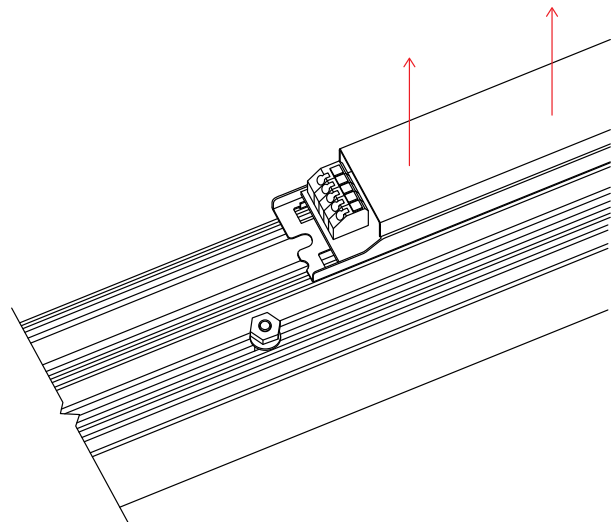

### TROUBLESHOOTING TIPS

- Do not reset the breaker multiple times.
- If the unit is overloaded, the breaker will trip, shutting off the driver and lights.
- If the breaker reset button has been held down by hand or any type of pressure, such as duct tape, or if the breaker has been reset multiple times without troubleshooting, the unit will:
  - Burn the driver bobbin.
  - Burn the thermal or magnetic breaker.
  - Burn the driver lead wires due to high amperage caused by overload.
  - Short circuit in line which will not allow the breaker to reset.
  - Damage the lighting.

- 1 Turn off power before beginning. Check for any twisting or damage to the circuit in the LED lightstrip. If there is excessive damage and the circuit is broken, the lightstrip must be replaced.

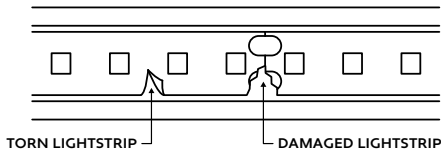

- 2 Check for metal particles or other foreign objects causing the short.

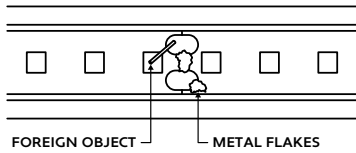

- 3 Check to make sure cuts in the lightstrip are clean and not frayed, causing positive and negative copper pads to touch.

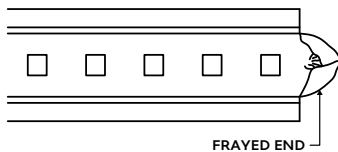

### CONTINUITY TEST

A continuity test is performed to determine if electricity can pass through two points on an electrical circuit. This helps identify shorts or malfunctions in the luminaire. Use a multimeter or continuity tester to perform the steps below.

- Always perform a continuity test before connecting to power source.
- Malfunctions are not always as obvious as the lights not turning on.
- A short or malfunction in the line or luminaire will cause damage over time, irreparably damaging the lighting and voiding warranty.

- 1 Turn off power before beginning. Verify power is off by using a non-contact circuit tester (by others). Touch the probe of the tester to the positive wire of the power source. The tester will light up if an electrical current is detected.

- 2 Setup your multimeter tester (by others). First, insert the black probe lead into the COM jack, then insert the red probe lead into the VΩ jack.

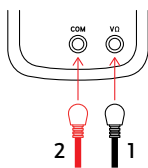

- 3 Touch the red probe to the luminaire extrusion and the black probe to the ground wire (green). If the luminaire is properly grounded, the multimeter will beep, flash, or read 0Ω (ohms). If there is no conductive path, the multimeter will not show any feedback. Troubleshoot to identify the malfunction in the ground wire.

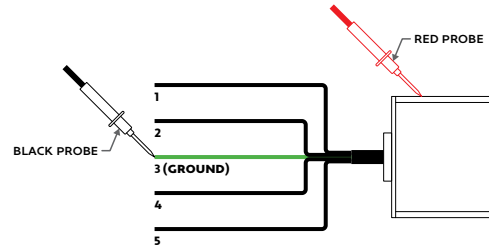

- 4 Touch the red probe to any wire and the black probe to each other wire. Repeat process for each wire. If a conductive path is formed between any of the wires, the multimeter will beep, flash, or read 0Ω (ohms). Troubleshoot to identify the malfunction in the line. If there is no conductive path, the multimeter will not show any feedback.

**Example:** Check for continuity between Wire 2 and Wire 4

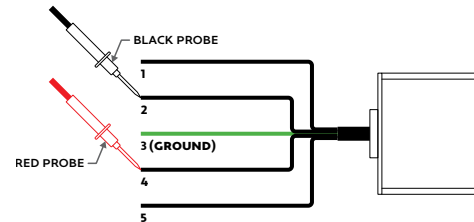

- 5 Touch the red probe to the luminaire housing and the black probe to each wire except ground. If a conductive path is formed between the housing and any of the wires, the multimeter will beep, flash, or read 0Ω (ohms). Troubleshoot to identify the malfunction in the line. If there is no conductive path, the multimeter will not show any feedback.

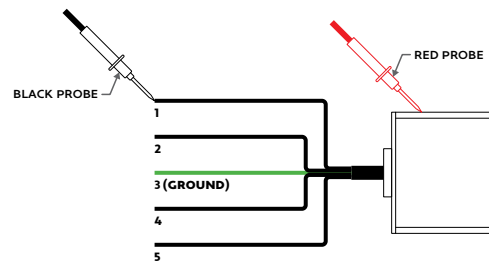

- 6 Set multimeter to AC voltage and test power source. Confirm the correct voltage before connecting luminaire to power source. If the voltage reading is more than 1 volt greater than the marked output voltage, there is a problem with the power source or driver.

- 7 Connect luminaire to power source. If LEDs do not turn on, troubleshoot to find the problem in the line.

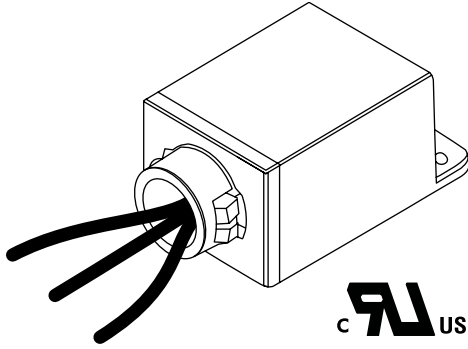

### CASE DIMENSIONS

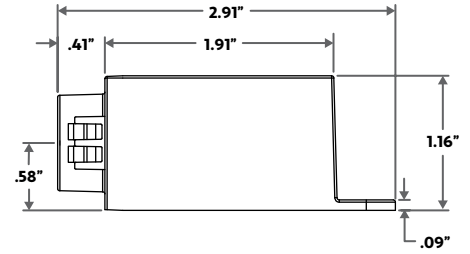
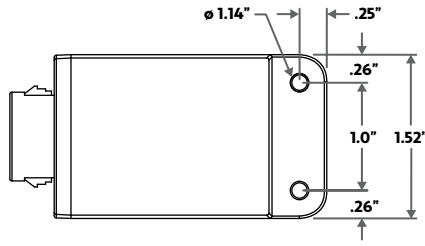

### SURGE PROTECTOR SPECIFICATIONS

Model	Input Voltage	Surge Protection Level	Mounting	Enclosure Material	Input Needs	Input Frequency
ALS-SP	120V - 277V	0kV, 10kA, ANSI C62.41 Category C	SnapLOCK / Footed	Polycarbonate	6", 18AWG stranded, 105°C stripped, 3/8" tinned	60Hz

### PRODUCT FEATURES

The Surge Series are 3-leaded devices that protect Line-Ground, Line-Neutral, and Neutral-Ground in accordance with IEEE / ANSI C62.41.2 guidelines. Protects against surges according to IEEE C62.41.2 C High (10kA and 10kV). Surge current rating = 10,000 Amps using industry standard 8/20 Sec wave. Surge Location Rated Category C3. UL Recognized Component in the United States and Canada (UL1449). Type 4 Surge Protection Device. High temperature, flame retardant plastic enclosure, 85°C maximum surface temperature rating. Thermally Protected Transient Over-voltage Circuit.

### PRODUCT SPECIFICATIONS

The Surge series of products are designed to be used in conjunction with LED Drivers and fixtures to provide an additional level of protection against powerline disturbances in industrial, commercial and residential applications where surge protection to IEEE C62.41.2 is required.

### DMX DIMMING WITH DECODER WIRING DIAGRAM

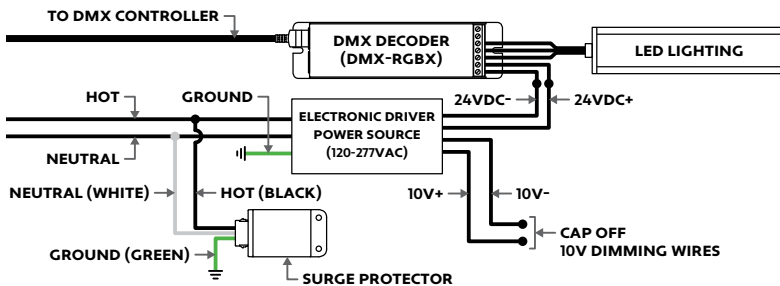

### DMX DIMMING WITH ALL-IN-ONE DRIVER WIRING DIAGRAM

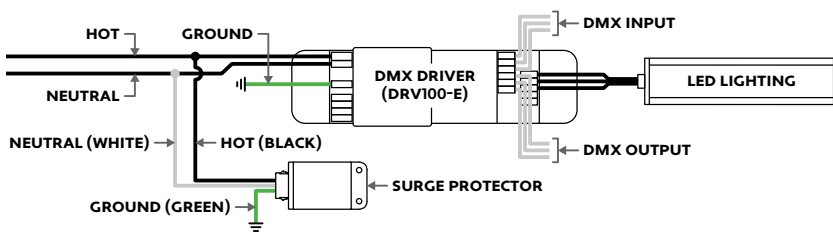

### DALI DIMMING WITH ALL-IN-ONE DRIVER WIRING DIAGRAM

