

Perspective View

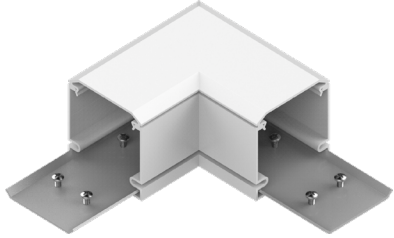

Assembled Dimensions

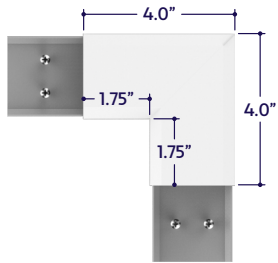

- 1 Measure area where luminaire will be installed. Plan locations where miter corners will be installed with fixtures. Use a laser line to create a reference line along installation area, ensuring consistent alignment of extrusions.
- 2 Remove top covers from miter corner to access internal wiring raceway. Set the covers to the side for now.

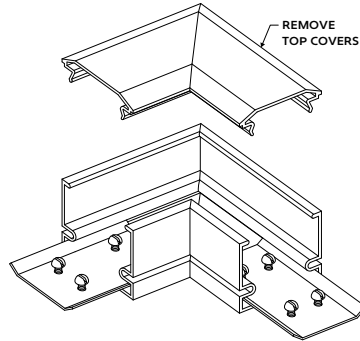

- 3 Butt fixture extrusions to miter corner, leaving no gaps. Make connections between miter corner and extrusion using included connector plates. Ensure all 4 screws are securely fastened, 2 on each side.

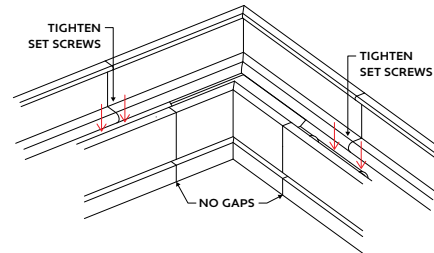
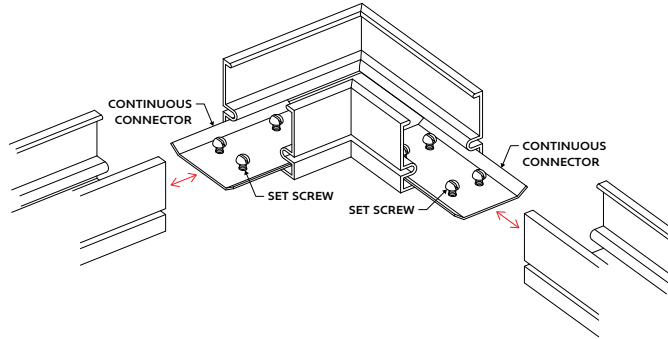

A6 Series | Mirror / Marquee ZEMY Standard - Flat Elbow (A6-ZEMY-STN-FE-90D)

- 4 Drill holes through the bottom surface of extrusion for mounting. Drill at least 1 hole per miter section. Mount miter corners to surface using an appropriate screw type and length for material surface.
Note: Use at least 2 screws for this miter.

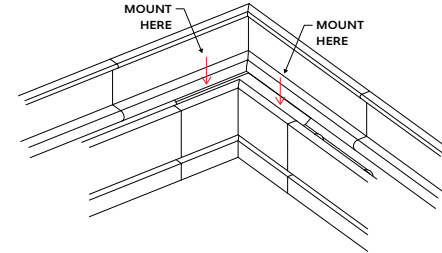

- 5 Make wiring connections between fixtures and miter corners using wire nuts (by others). Use outdoor rated wire nuts for wet location applications. Use the fixture and miter extrusions as raceway to contain connections.
- 6 Perform a continuity test before installing lamps or connecting fixtures to power source.
Note: Refer to installation instructions for specific details on continuity test.
- 7 After fixtures are confirmed to be working, replace top covers to fixtures and miter corners, then install lamps.

