

ZOMU Recessed Low

A8-ZOMU-RCL

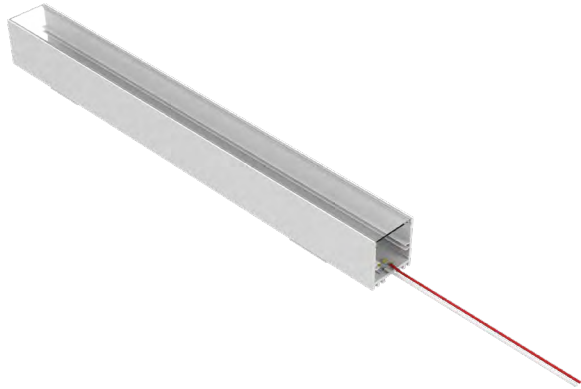

GENERAL FEATURES

Applications	Accent, Decorative, Surface, Recessed, Pendant Lighting
Lens	Clear, 50% Semi-Frosted, or 100% Frosted
Viewing Angle	120°
Length	Built to Order (+/- 1/8" Tolerance)
Construction	Aluminum Extrusion
Weight	0.269 lbs per foot
Mounting	Mounting Channel or Mounting Clips (Sold Separately)
Listing	Dry Location UL2108, CSA C22.2 #9 UL8750, CSA250
Temperature Ratings	Operating / Startup: -20° to 48°C (-4° to 120°F) Storage: -40° to 76°C (-40° to 170°F)
Installation Link	

ELECTRICAL

Dimming	DMX
Maximum Run (Class 1 Applications)	13' (9W) 16' (7.2W)
Maximum Run (Class 2 Applications)	10' (9W) 13' (7.2W)
Luminaire Voltage	24V DC

PRODUCT INFORMATION

- For accent, decorative, surface, recessed, or pendant lighting.
- 24 Volts DC for easy and safe installation.
- Long life, energy efficient LEDs.
- Can be ordered to specific lengths for when exact dimensions are known
Example: 10 x 10'6"
- Plug and light system.
- Lead wires are typically 36" long and exit on one end.

READ ENTIRE GUIDE BEFORE STARTING INSTALLATION

Important Notice: Verify correct luminaire was received with correct color temperature, voltage, and wattage before cutting or installing. ALUZ will not be responsible if incorrect luminaire is installed.

END VIEW / DIMENSIONS

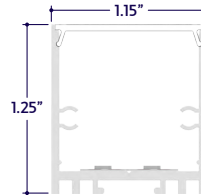

ELECTRICAL REQUIREMENTS

- Luminaires require a 24 Volt DC remote driver.
- To calculate driver size, determine Watts per Foot.
Example: 8W per Foot
- Determine Length in Feet.
Example: 5'6"
- Calculate Load: Multiply Watts per Foot x Length in Feet
Example: 8W x 5'6" = ~45W
- Choose a driver from catalog.
Example: 60 Watt Driver
- Determine maximum driver distance using Maximum Wire Length Table on drivers page.
Example: 45 watts is between 40W and 60W. Using #14 wire, maximum distance is 37' from driver to first LED.

INSTALLATION RECOMMENDATIONS

- Luminaires must be mechanically attached directly to mounting surface using mounting clips, channels, or other appropriate means. Refer to installation step by step pages for details.
- Conduit raceway should be sleeved at one end for low voltage wires going to driver.

INSTALLATION TOOLS REQUIRED

- Electric Hammer Drill
- 14.4 to 28 Volt Cordless Drill
- Phillips Bits
- Utility Knife
- Electrical Cord
- Marker
- Wire Stripper
- Long Nose Pliers
- Drill Bits - Concrete or Wood
- Electrical Three Ways
- Safety Glasses
- Measuring Tape
- Laser Line or Chalk Line

WARNING

When using LED Lightstrip for any application, basic safety precautions should always be followed to reduce the risk of fire, electric shock, and personal injury. LED Lightstrip must be installed in accordance with the NEC or CEC as applicable. ALUZ will not be responsible for any damage or malfunction caused by the following:

- Ensure power is off before installation begins, during replacements, additions, or repairs.
- Do not use LED Lightstrip if damaged, such as broken boards, loose connections, or frayed wire insulation. Inspect before installing.
- Do not install LED Lightstrip in hazardous locations.
- Do not cover LED Lightstrip with any material, as it may cause LEDs to overheat, melt, or ignite. (Fig. 1)
- Do not paint on or over fixture lens or LEDs. Paint or any other substance on lens or LEDs will cause a shift in color temperature.
- Soffit must be evenly painted with a neutral white to avoid color shift.
- Do not modify LED Lightstrip in the field.
- Do not overlap LED Lightstrip luminaires in any way.
- Only use LED Lightstrip with specified rated voltages. Do not exceed the specified voltage for any LED Lightstrip luminaire.
- Do not use LED Lightstrip extrusion as a raceway for additional wire. Non-factory feed through wires inside LED Lightstrip will void warranty.
- Ground Fault Circuit Interrupter (GFCI) protections should be provided on circuits or outlets when LED Lightstrip is used for outdoor applications.
- Surge protector must be set up for electrical power system to avoid damaging LED Lightstrip lighting system.
- Do not connect wires together, follow provided wiring diagrams.
- Do not cut wire while energized.
- Do not connect LED Lightstrip lightstrip to power source while spooled or coiled. (Fig. 2)
- Do not exceed maximum run lengths.
- Do not mount LED Lightstrip with staples, nails, or like means that might damage the insulation. Mount with double-sided tape and mounting clips.
- Do not install mounting clips over LED diodes. (Fig. 3)
- Do not penetrate LED Lightstrip lightstrip with any foreign object. (Fig. 4)
- Do not mount LED Lightstrip inside tanks or enclosures of any kind.
- Do not use improper screw head type on mounting clips. It will cause the mounting clip to open up and become dysfunctional.
- Do not modify mounting clips.
- Do not mount fixture with less than the minimum number of mounting clips required. See mounting clips section for details.
- Do not force LED Lightstrip into a space that is too small.
- Do not force LED Lightstrip with cord grip into soffit.
- Do not install LED Lightstrip at an angle within a cove. Only install fixtures straight within a cove.
- Do not bend extrusion around radius.
- Do not submerge dry or wet location LED Lightstrip in any liquid.
- Do not install wet location in outdoor coves without proper drainage. (Fig. 5)
- Do not install LED Lightstrip in any area that is continuously exposed to flowing or pooling water, such as underneath drain pipes, sprinklers, fountains, misters, etc.
- Do not install connectors without shrink tube for wet location. (Fig. 6)
- Do not use a lighter or open flame to heat shrink tube. (Fig. 7)
- Do not cut, puncture, or penetrate LED Lightstrip aluminum housing, end caps, or lens covers.
- Do not drop, bang, or rest weight upon LED Lightstrip.
- Do not apply excessive pressure to any part of LED Lightstrip lightstrip or LEDs. (Fig. 8)
- Do not bend LED Lightstrip power cord or continuous connector past permitted bend radius. Bending past permitted bend radius will break the seal of the cordgrip or damage the insulation. 1.5" minimum bend radius. (Fig. 9)
- Do not install LED Lightstrip lightstrip in a zig zag fashion. (Fig. 10)
- Do not fold, crease, or twist LED Lightstrip lightstrip. (Fig. 11)
- Do not bend lightstrip along a horizontal plane. (Fig. 12)
- Do not overlap LED Lightstrip at any location. (Fig. 13)
- Do not cross or overlap extrusions and twist lightstrip to overlap. (Fig. 14)
- Do not install LED Lightstrip in places where the power cord is subject to continuous flexing.
- Do not twist continuous connector or power cord.
- Do not hold, carry, or suspend LED Lightstrip by the power cord.
- Do not install LED Lightstrip on ceilings without mounting clips. (Fig. 15)

FIGURES

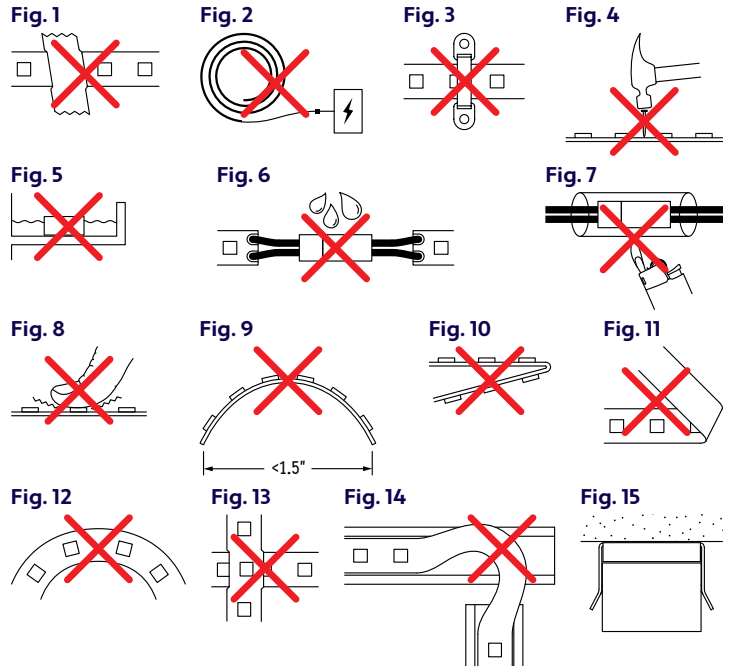

CLEANING MATERIALS

The use of solvents and/or cleaners which are not compatible with polycarbonate will result in the softening, crazing, and/or cracking of the plastic part. This is especially true of polycarbonate lamps and mounting bases which may be under stress in their normal applications.

COMPATIBLE WITH POLYCARBONATE

- | | |
|-------------------------------------------------------------------------------------------------------------------------------------------------------------------------------------------------------------------------------------------------------------------------|---------------------------------------------------------------------------------------------------------------------------------------------------------------------------------------------------------------------------------------------------------------------------------------------------|
| <ul style="list-style-type: none"> • Mild soap and water • Mineral Spirits • Isobutyl Alcohol • VM and P Naphtha • Varsol No.2 • Mexane • Freone TF and TE-35 • Ethanol • Dirtex | <ul style="list-style-type: none"> • 2% Sol. Reg. Joy • 10% Sol Bon Ami • White Kerosene • Methyl Alcohol • Heptane • Petroleum Ether / 65°C • Isopropyl Alcohol • Lacryl PCL-2035 • Polycarbonate Cleaner |
|-------------------------------------------------------------------------------------------------------------------------------------------------------------------------------------------------------------------------------------------------------------------------|---------------------------------------------------------------------------------------------------------------------------------------------------------------------------------------------------------------------------------------------------------------------------------------------------|

NOT COMPATIBLE WITH POLYCARBONATE

- | | |
|-------------------------------------------------------------------------------------------------------------------------------------------------------------------------------------------------------------------------------------------------------------------------------------------------------------------------------------------------------------------------------------------------|------------------------------------------------------------------------------------------------------------------------------------------------------------------------------------------------------------------------------------------------------------------------------------------------------------------------|
| <ul style="list-style-type: none"> • Trichlor • Gasoline • Liquid Detergents • Acetone • Carbon Tetrachloride • Pink Lux (Phosphate free) • Triclene • Chlorinated Hydrocarbons • #1 & #3 Denatured Alcohol • Methyl Ethyl Keytone (MEK) • Texize-8006, 8129, 8758 • MIBK | <ul style="list-style-type: none"> • Liquid Cleaner - 8211 • Toluol • Agitene • Benzol • Ajax • Kleenol Plastics • Lysol • Stanisol Naphtha • Oils • Lemon Joy (phosphate free) • Diversol • Lestoil |
|-------------------------------------------------------------------------------------------------------------------------------------------------------------------------------------------------------------------------------------------------------------------------------------------------------------------------------------------------------------------------------------------------|------------------------------------------------------------------------------------------------------------------------------------------------------------------------------------------------------------------------------------------------------------------------------------------------------------------------|

DIAGRAM OF DRIVER

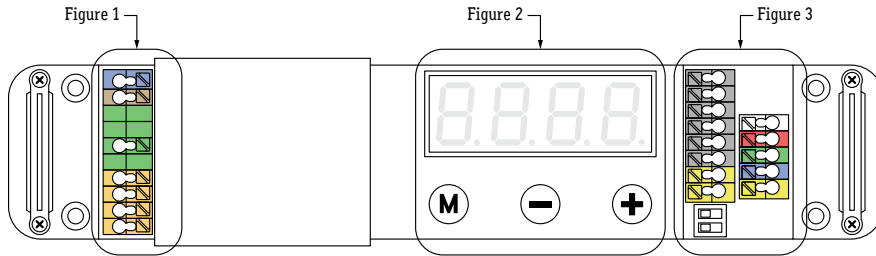

FIGURE 1 (INPUT)

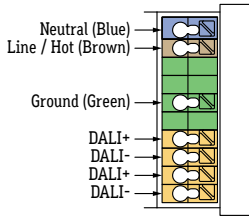

FIGURE 2 (INTERFACE)

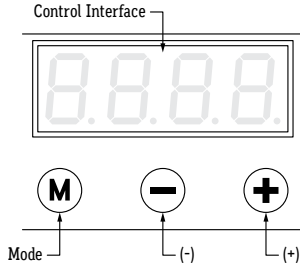

FIGURE 3 (DMX OUTPUT)

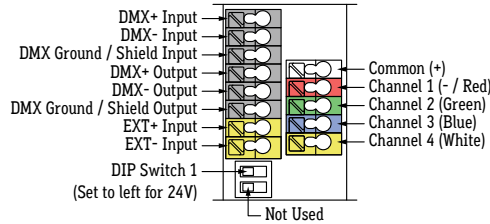
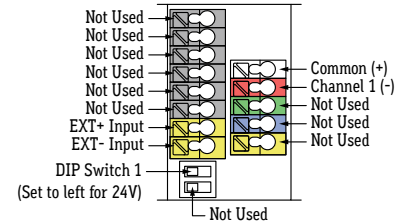
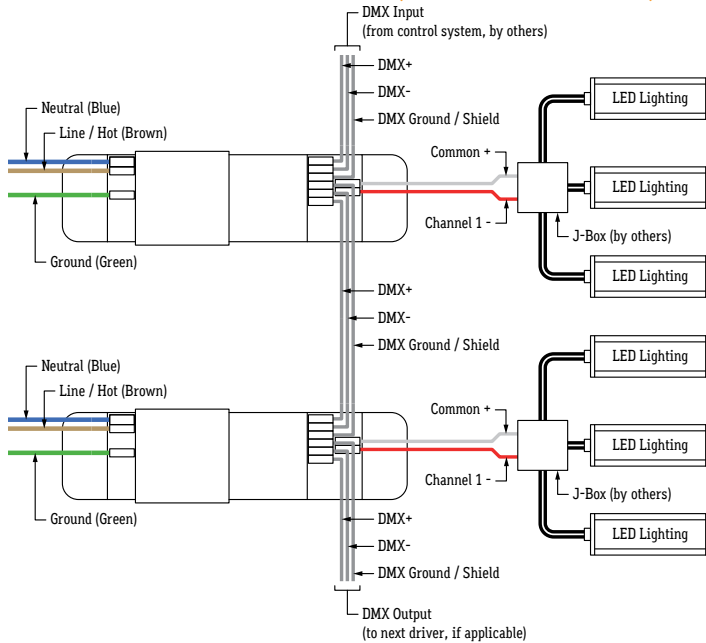

FIGURE 4 (DALI OUTPUT)



TYPICAL DAISY CHAIN LAYOUT (DMX STATIC COLOR)



NOTES (DMX)

- Default DMX address of each luminaire is 001. Consult third party DMX commissioner to modify at time of installation. ALUZ does not provide DMX commissioning.
- DMX Address must be set for each driver. Default DMX address for each driver is 001.
- A DMX Control System (by others) must be used to operate the system.
- The last driver in a daisy chain sequence must be terminated.
- Up to 28 drivers may be daisy chained together using shielded cable specified for DMX wiring.
- Wire colors on diagram correspond to colors of driver terminals.
- Driver load not to exceed 96W.
It is recommended to only load drivers to 80% for best dimming performance.
- Ensure DIP Switch 1 is set to ON (Left) to activate 24V operation.

TYPICAL DAISY CHAIN LAYOUT (DALI STATIC COLOR)

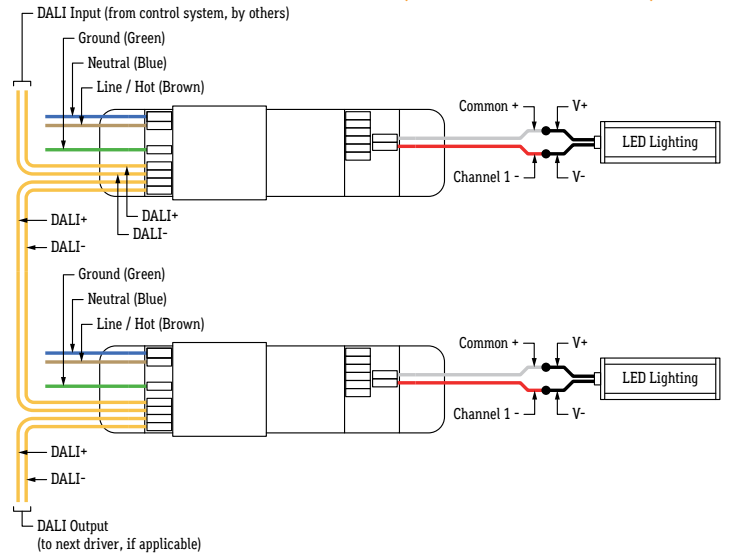

NOTES (DALI)

- DALI commissioning to be performed by a third party at time of installation. ALUZ does not provide DALI commissioning.
- Wire colors on diagram correspond to colors of driver terminals.
- Driver load not to exceed 100W.
It is recommended to only load drivers to 80% for best dimming performance.
- A DALI Control System (by others) must be used to operate the drivers.
- Ensure DIP Switch 1 is set to ON (Left) to activate 24V operation.
- DALI Address must be set for each driver.
- Up to 28 drivers may be daisy chained together using shielded cable specified for DALI wiring.

MODE OF OPERATION

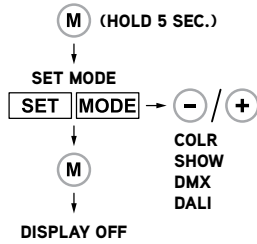

SET LED GROUPS

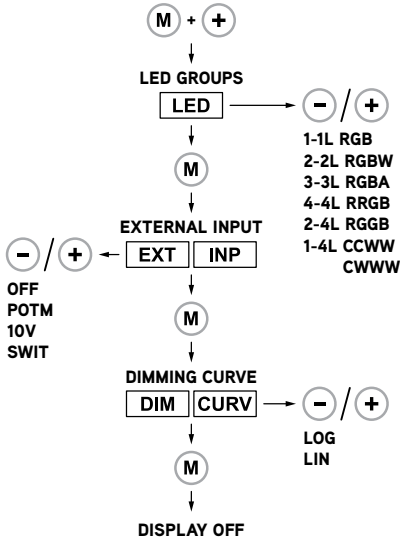

STANDALONE OPERATION (Color / Show)

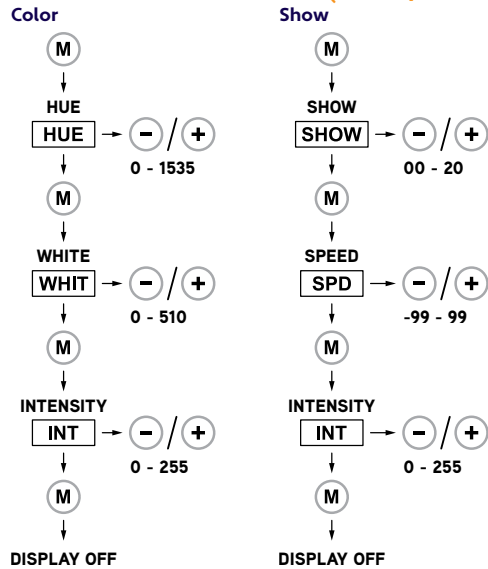

STANDALONE OPERATION (Network Operation)

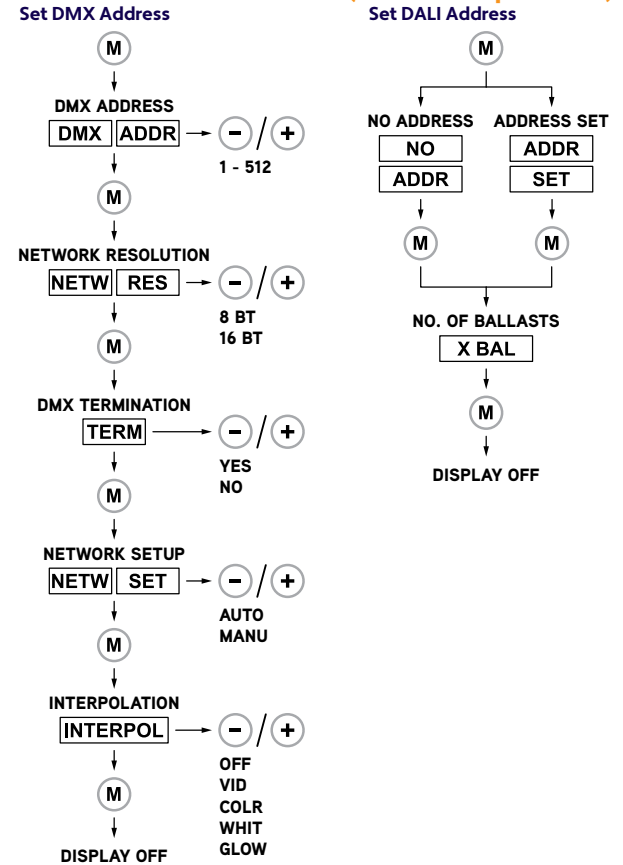

OTHER FUNCTIONS

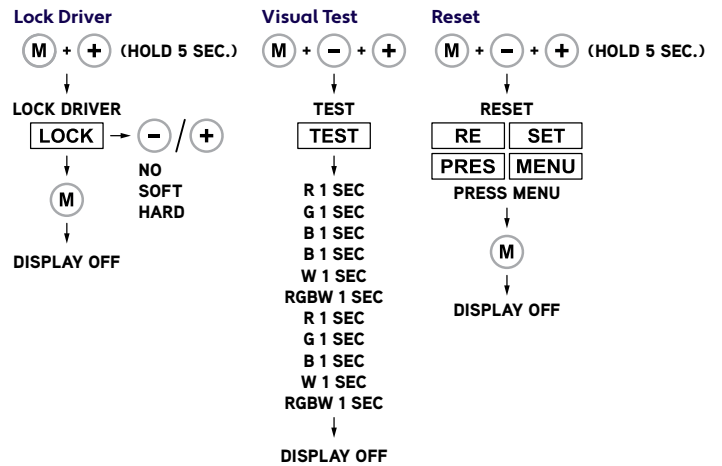

ZOMU Recessed Low

A8-ZOMU-RCL

UNASSEMBLED APPLICATIONS

- 1 Measure area where luminaire will be installed. Use a laser line to create a reference line along installation area, ensuring consistent alignment of mounting clips. Mark location where each mounting clip will be installed along reference line.
- 2 Use 1 mounting clip every 2', rounded up. Use a minimum of 2 mounting clips per luminaire segment. For vertical applications, create a stopper at the bottom of the run to prevent sliding.
- 3 Use a mounting clip at the junction between two luminaire segments.
Example: 20' Run.

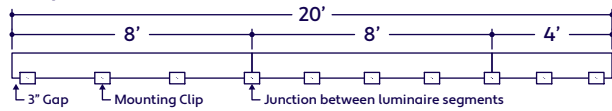

- 4 Lay mounting clips along reference line and pre-drill using an appropriate drill bit for surface material and screw size. Typical screw size is 8/32 x 1".
Note: Allow 1/4" clearance on each side of mounting clip to account for lateral expansion. Only install mounting clips on flat, even surfaces.
- 5 Screw mounting clips to surface, then snap luminaire into mounting clips.

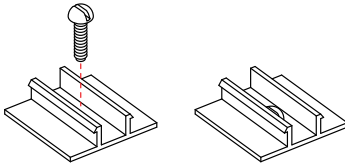

ASSEMBLED APPLICATIONS

- 1 Measure area where luminaire will be installed. Use a laser line to create a reference line along installation area, ensuring consistent alignment of mounting clips. Mark location where each mounting clip will be installed along reference line.
- 2 Use 1 mounting clip every 2', rounded up. Use a minimum of 2 mounting clips per luminaire segment. For vertical applications, create a stopper at the bottom of the run to prevent sliding.
- 3 Space mounting clips evenly throughout the run.
Example: 20' Run.

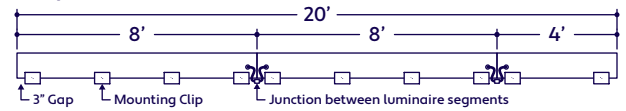

ASSEMBLED END VIEW

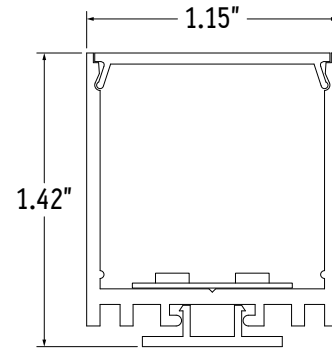

- 1 Measure area where fixtures will be installed. Use a chalk line to ensure a straight installation.
- 2 Lay extrusions along chalk line and drill at least 3 countersink holes per extrusion. Drill additional holes as needed.

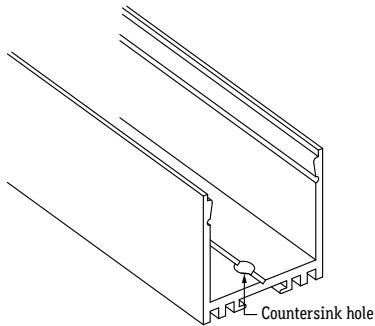

- 3 Screw extrusions to surface using countersink screws.
Note: Ensure extrusions are aligned. Misalignment will prevent lens from snapping in.

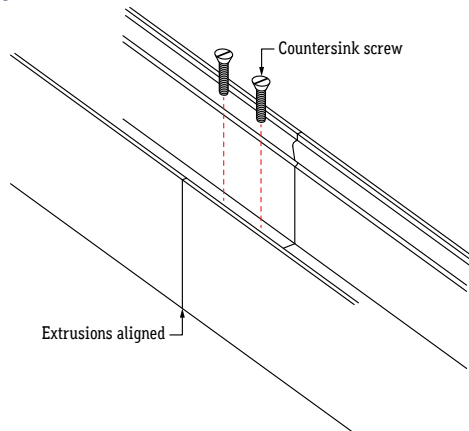

- 4 After all extrusions have been securely mounted, remove adhesive backing from lightstrip and stick in place along extrusion channel, ensuring lightstrip is secure inside extrusion.
Note: Refer to Application Guidelines to ensure correct installation.

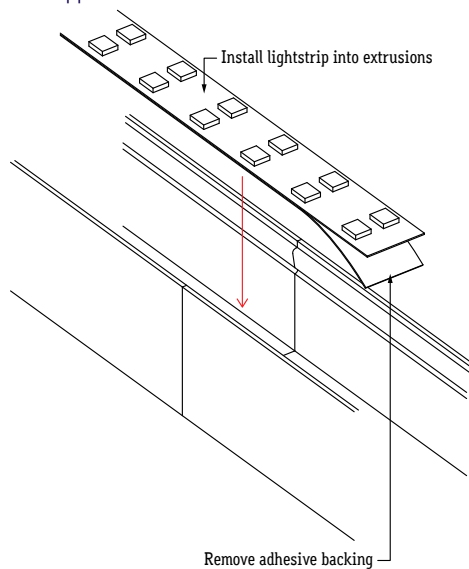

- 5 If applicable, connect disconnects between fixtures or solder connectors.
- 6 Install lens into extrusion, overlapping where two extrusions meet. Plan your cuts so that the lens will always overlap where two extrusions meet. Overlapping lenses helps keep extrusions aligned and prevents light leaks.

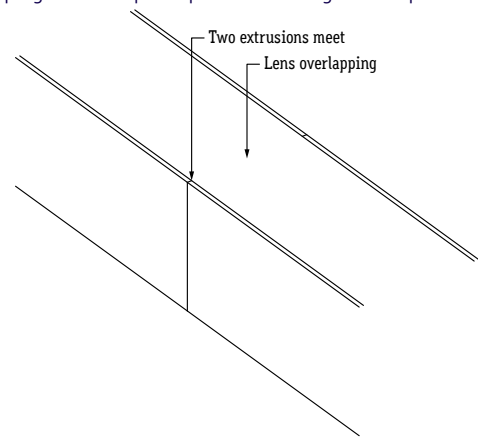

- 7 Perform a continuity test before connecting fixture to power source.

- 1 Measure area where fixtures will be installed. Use a chalk line to ensure a straight installation.
- 2 Mark location where mounting clips will be installed.
Note: The number of required mounting clips differs for dry and wet location products. Verify number of mounting clips is appropriate for installation environment before installing. Do not install fixtures with inadequate number of mounting clips.
- 3 Lay mounting clips and pre-drill using proper drill bit for surface and screw size.
Recommendation: 8/32 x 1" screw.
Note: Allow 0.25" clearance for lateral expansion of assembled mounting clips. Only install mounting clips on flat, even surfaces.

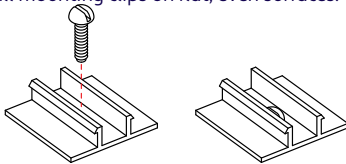

- 4 Screw mounting clips to surface, then snap extrusions into mounting clips.
Note: Ensure extrusions are aligned. Misalignment will prevent lens from snapping in.

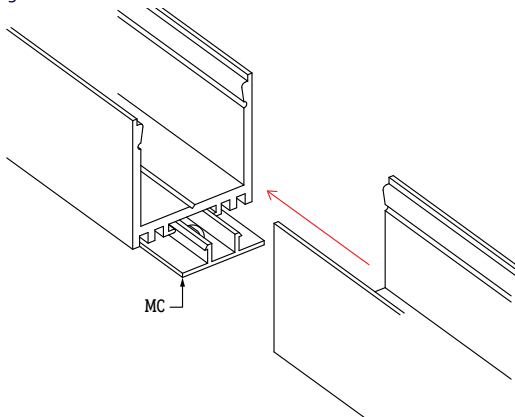

- 5 After all extrusions have been securely mounted, remove adhesive backing from lightstrip and stick in place along extrusion channel, ensuring lightstrip is secure inside extrusion.
Note: Refer to Application Guidelines to ensure correct installation.

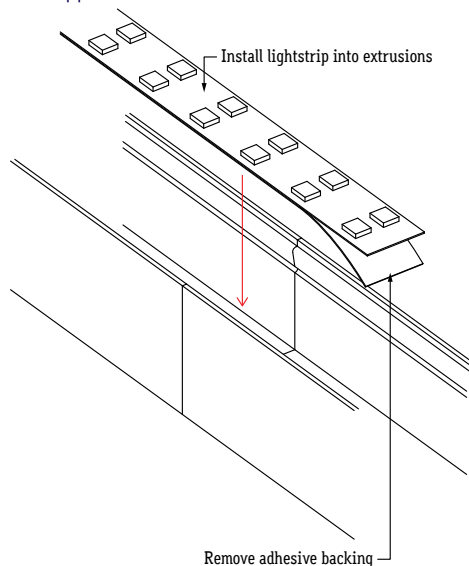

- 6 If applicable, connect disconnects between fixtures or solder connectors.
- 7 Install lens into extrusion, overlapping where two extrusions meet. Plan your cuts so that the lens will always overlap where two extrusions meet. Overlapping lenses helps keep extrusions aligned and prevents light leaks.

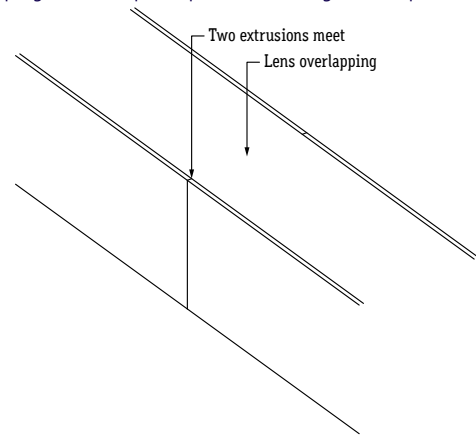

- 8 Perform a continuity test before connecting fixture to power source.

